

# MARKET STREET—WELLS FARGO BRANCH BANK SITE PLAN MINOR PLAN REVIEW

4195 MARKET STREET, WILMINGTON, NC 28403

## VICINITY MAP

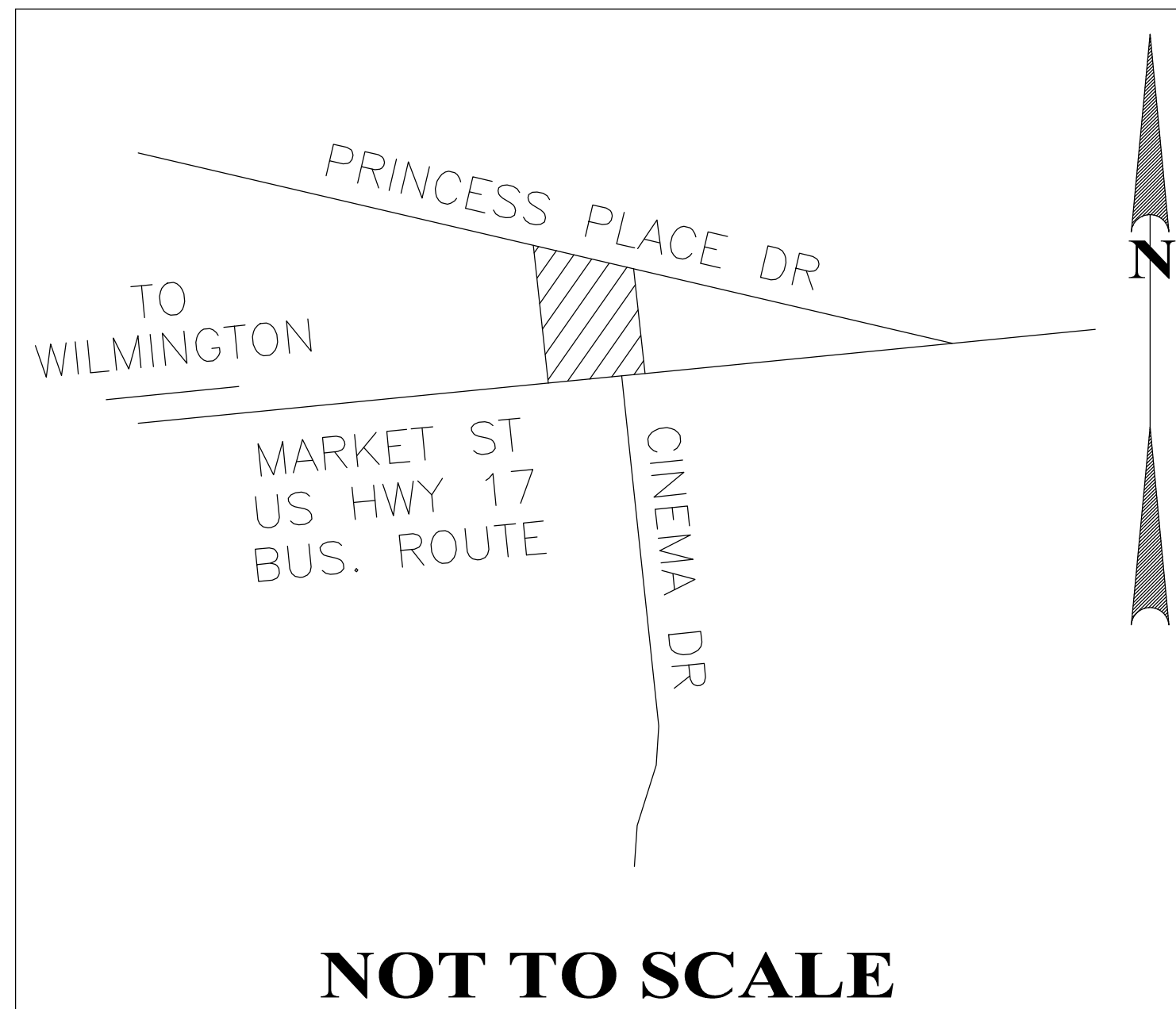

## INDEX OF DRAWINGS

C0.00	COVER SHEET
C1.00	EXISTING CONDITIONS SURVEY
C1.01	OVERALL EXISTING CONDITIONS
C2.00	DEMOLITION PLAN
C3.00	SITE LAYOUT PLAN
C4.00	GRADING & EROSION CONTROL PLAN
C5.00	SITE DETAILS
C5.01	EROSION CONTROL DETAILS
L1.00	LANDSCAPE PLAN

## PROJECT INFORMATION

**PLANS PREPARED BY:**  
LITTLE DIVERSIFIED ARCHITECTURAL CONSULTING

**OWNER INFORMATION:**  
JIM ROCK, CCIM, CPM  
VICE PRESIDENT  
WELLS FARGO CORPORATE PROPERTIES GROUP  
822 PEBBLE DRIVE  
GREENSBORO, NC 27410  
336-202-0606

**REQUIRED PERMITS:**  
THIS PROJECT REQUIRES CITY OF WILMINGTON MINOR  
PLAN REVIEW PERMIT AND NCDOT DRIVEWAY PERMIT

### SITE DATA:

PARCEL ID	R04914-008-005-001
ZONING DISTRICT	CITY
TOTAL SITE AREA	1.10 AC.
BUILDING AREA	3,100 S.F.
BUILDING HEIGHT	+/-20'-0"

## GENERAL NOTES

- ALL TRAFFIC CONTROL SIGNAGE AND STRIPING TO CONFORM TO THE MANUAL ON UNIFORM TRAFFIC CONTROL DEVICES (M.U.T.C.D.). UNIFORM TRAFFIC CONTROL DEVICES (M.U.T.C.D.).
- ALL PAVING CUTS SHALL BE MADE BY SAW CUTS. EXISTING ELEVATIONS SHALL BE FIELD VERIFIED AND MATCHED.
- CONTRACTOR TO COORDINATE ANY CHANGES IN FIELD CONDITIONS THAT MAY REVISE THE DESIGN WITH ARCHITECT / ENGINEER PRIOR TO PROCEEDING.
- ALL DIMENSIONS ARE FROM FACE OF CURB.
- CONTRACTOR IS RESPONSIBLE TO REPLACE AND/OR REPAIR ANY DAMAGES TO THE EXISTING LANDSCAPE, IRRIGATION, POWER AND/OR HARDSCAPE.

**LITTLE**  
DIVERSIFIED ARCHITECTURAL CONSULTING

5815 Westpark Drive Charlotte, NC 28217  
T: 704.525.6350 F: 704.561.8700

www.littleonline.com

*This drawing and the design shown are the property of Little Diversified Architectural Consulting. The reproduction, copying or other use of this drawing without their written consent is prohibited and any infringement will be subject to legal action.*

© Little 2014

**WELLS  
FARGO**

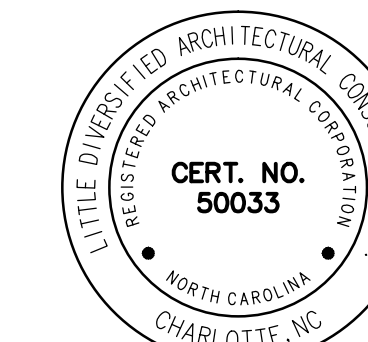

6-10-14  
ISSUE FOR

ISSUE DATE  
**06 JUNE 2014**

NO.	REASON	DATE
01	06/06/2014 PRICING DOCUMENTS	
02	06/09/2014 PLANNING SUBMITTAL	
03	07/11/2014 PLANNING RE-SUBMITTAL	
04	07/11/2014 NCDOT RE-SUBMITTAL	
05	07/28/2014 PLANNING RE-SUBMITTAL	
06	07/28/2014 NCDOT RE-SUBMITTAL	

**PROJECT TEAM**  
PRINCIPAL IN CHARGE  
Nancy Everhart, AIA, LEED AP  
PROJECT MANAGER  
Dennis C. Terry, RLA  
DESIGN TEAM

**PROJECT NAME**  
WELLS FARGO  
4195 MARKET ST.  
WILMINGTON, NC

**PROJECT NUMBER**  
123.2814.00

**SHEET TITLE**  
COVER SHEET

**SHEET NUMBER**  
**C0.00**

**WILMINGTON**  
NORTH CAROLINA  
Public Services • Engineering Division  
APPROVED PLAN – NO PERMIT REQUIRED  
Signed: \_\_\_\_\_



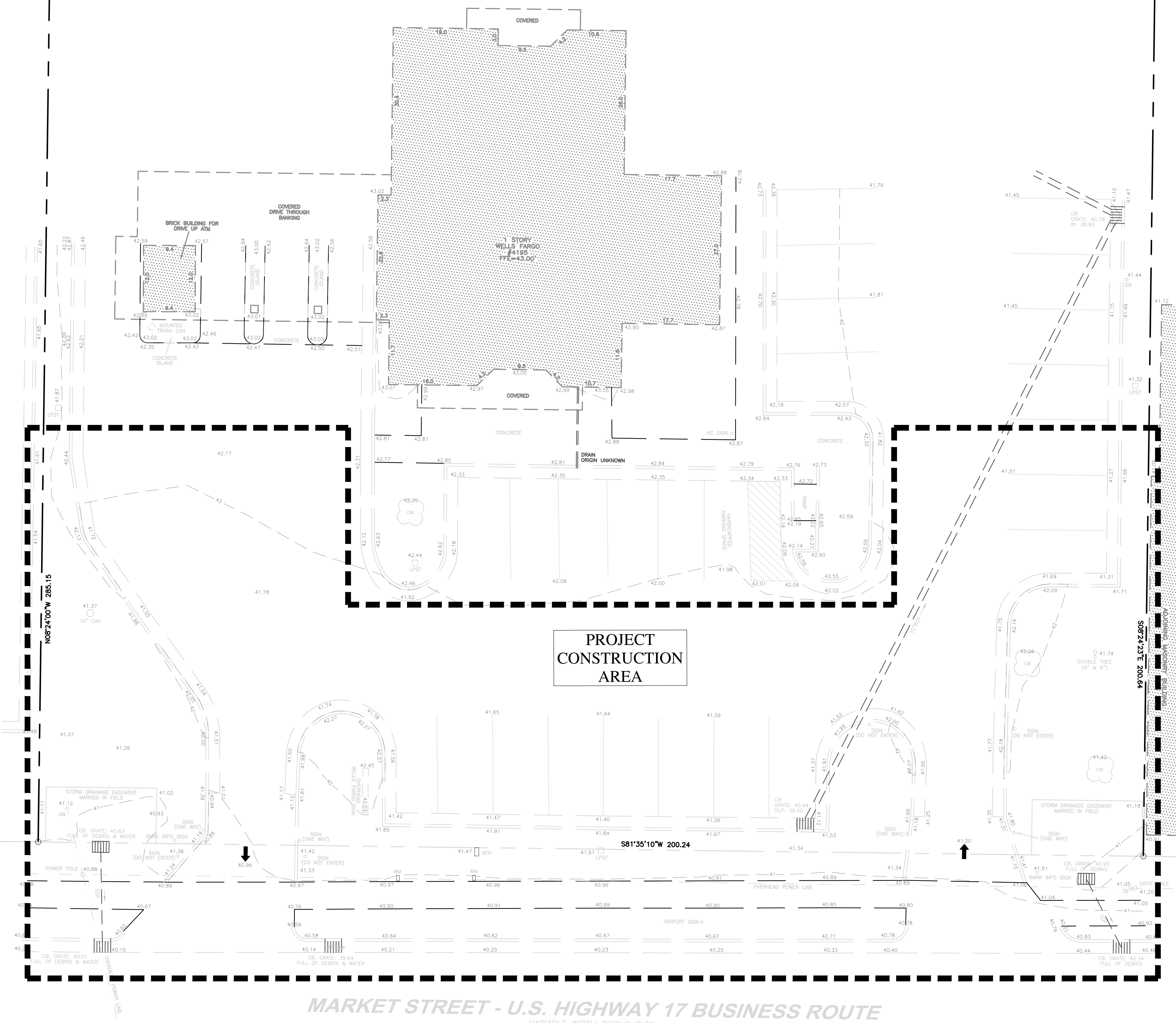

PROJECT  
CONSTRUCTION  
AREA

MARKET STREET - U.S. HIGHWAY 17 BUSINESS ROUTE  
VARIABLE WIDTH PUBLIC R/W

THIS PLAN IS PROVIDED FOR INFORMATIONAL PURPOSES ONLY. THIS PLAN IS PREPARED BY OTHERS. LITTLE DIVERSIFIED ARCHITECTURAL CONSULTING IS NOT RESPONSIBLE FOR ANY ERRORS OR OMISSIONS FROM THIS SURVEY.

**WILMINGTON**  
NORTH CAROLINA  
Public Services • Engineering Division  
APPROVED PLAN - NO PERMIT REQUIRED  
Signed: \_\_\_\_\_

**LITTLE**  
DIVERSIFIED ARCHITECTURAL CONSULTING  
5815 Westpark Drive Charlotte, NC 28217  
T: 704.525.6350 F: 704.561.8700  
www.littleonline.com

This drawing and the design shown are the property of Little Diversified Architectural Consulting. The reproduction, copying or other use of this drawing without their written consent is prohibited and any infringement will be subject to legal action.  
© Little 2014



ISSUE FOR

ISSUE DATE

06 JUNE 2014

NO.	REVISIONS	DATE
01	06/06/2014 PRICING DOCUMENTS	
02	06/09/2014 PLANNING SUBMITTAL	
03	07/11/2014 PLANNING RE-SUBMITTAL	
04	07/11/2014 NCDOT RE-SUBMITTAL	
05	07/28/2014 PLANNING RE-SUBMITTAL	
06	07/28/2014 NCDOT RE-SUBMITTAL	

PROJECT TEAM  
PRINCIPAL IN CHARGE  
**Nancy Everhart, AIA, LEED AP**  
PROJECT MANAGER  
**Dennis C. Terry, RLA**  
DESIGN TEAM

PROJECT NAME  
**WELLS FARGO**  
**4195 MARKET ST.**  
**WILMINGTON, NC**

PROJECT NUMBER  
**123.2814.00**  
SHEET TITLE  
EXISTING CONDITIONS SURVEY

SHEET NUMBER  
**C1.00**



F:\SDS\Site\Civil\101-2814-00 Wilmington Wells Fargo\Site\CD's\C1.01 Overall Existing Conditions.dwg Jul 30, 2014-12:20pm

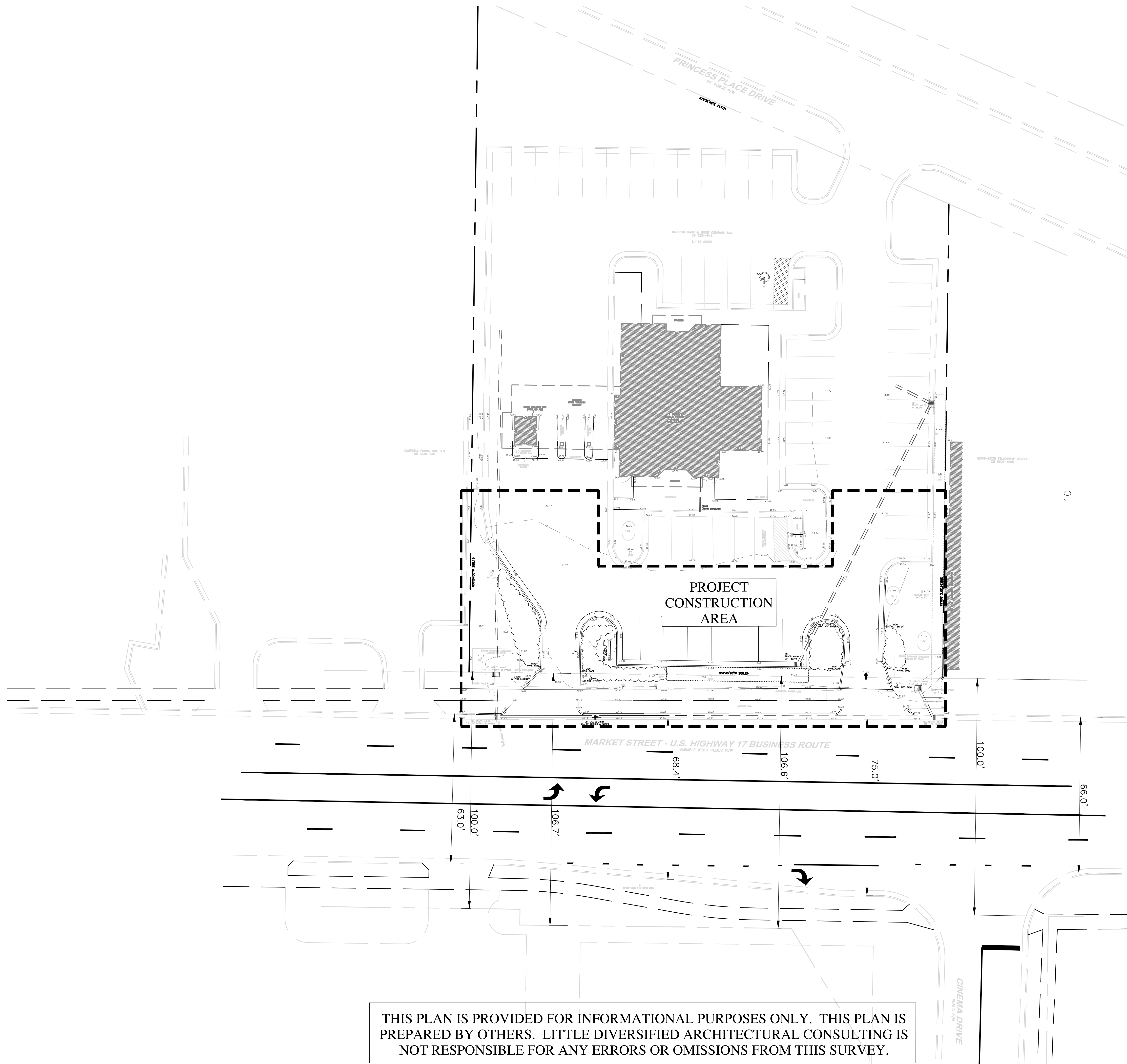

THIS PLAN IS PROVIDED FOR INFORMATIONAL PURPOSES ONLY. THIS PLAN IS PREPARED BY OTHERS. LITTLE DIVERSIFIED ARCHITECTURAL CONSULTING IS NOT RESPONSIBLE FOR ANY ERRORS OR OMISSIONS FROM THIS SURVEY.

  
 CITY OF WILMINGTON  
 NORTH CAROLINA  
 Public Services • Engineering Division  
 APPROVED PLAN - NO PERMIT REQUIRED  
 Signed: \_\_\_\_\_

SCALE: 1" = 20'-0"

1. OVERALL EXISTING CONDITIONS PLAN

**LITTLE**  
 DIVERSIFIED ARCHITECTURAL CONSULTING  
 5815 Westpark Drive Charlotte, NC 28217  
 T: 704.525.6350 F: 704.561.8700  
 www.littleonline.com  
*This drawing and the design shown are the property of Little Diversified Architectural Consulting. The reproduction, copying or other use of this drawing without their written consent is prohibited and any infringement will be subject to legal action.*  
 © Little 2014







ISSUE FOR: **6-10-14**

ISSUE DATE: **06 JUNE 2014**

NO.	REVISIONS	DATE
01	06/06/2014 PRICING DOCUMENTS	
02	06/09/2014 PLANNING SUBMITTAL	
03	07/11/2014 PLANNING RE-SUBMITTAL	
04	07/11/2014 NCDOT RE-SUBMITTAL	
05	07/28/2014 PLANNING RE-SUBMITTAL	
06	07/28/2014 NCDOT RE-SUBMITTAL	

PROJECT TEAM  
 PRINCIPAL IN CHARGE: Nancy Everhart, AIA, LEED AP  
 PROJECT MANAGER: Dennis C. Terry, RLA  
 DESIGN TEAM:

PROJECT NAME:  
**WELLS FARGO**  
 4195 MARKET ST.  
 WILMINGTON, NC

PROJECT NUMBER:  
**123.2814.00**

SHEET TITLE:  
**OVERALL EXISTING CONDITIONS**

SHEET NUMBER:  
**C1.01**



F:\SDS\SiteCivil\101-2814-00 Wilmington Wells Fargo\Site\CD's\C2.00 Demolition Plan.dwg Jul 30, 2014-12:39pm

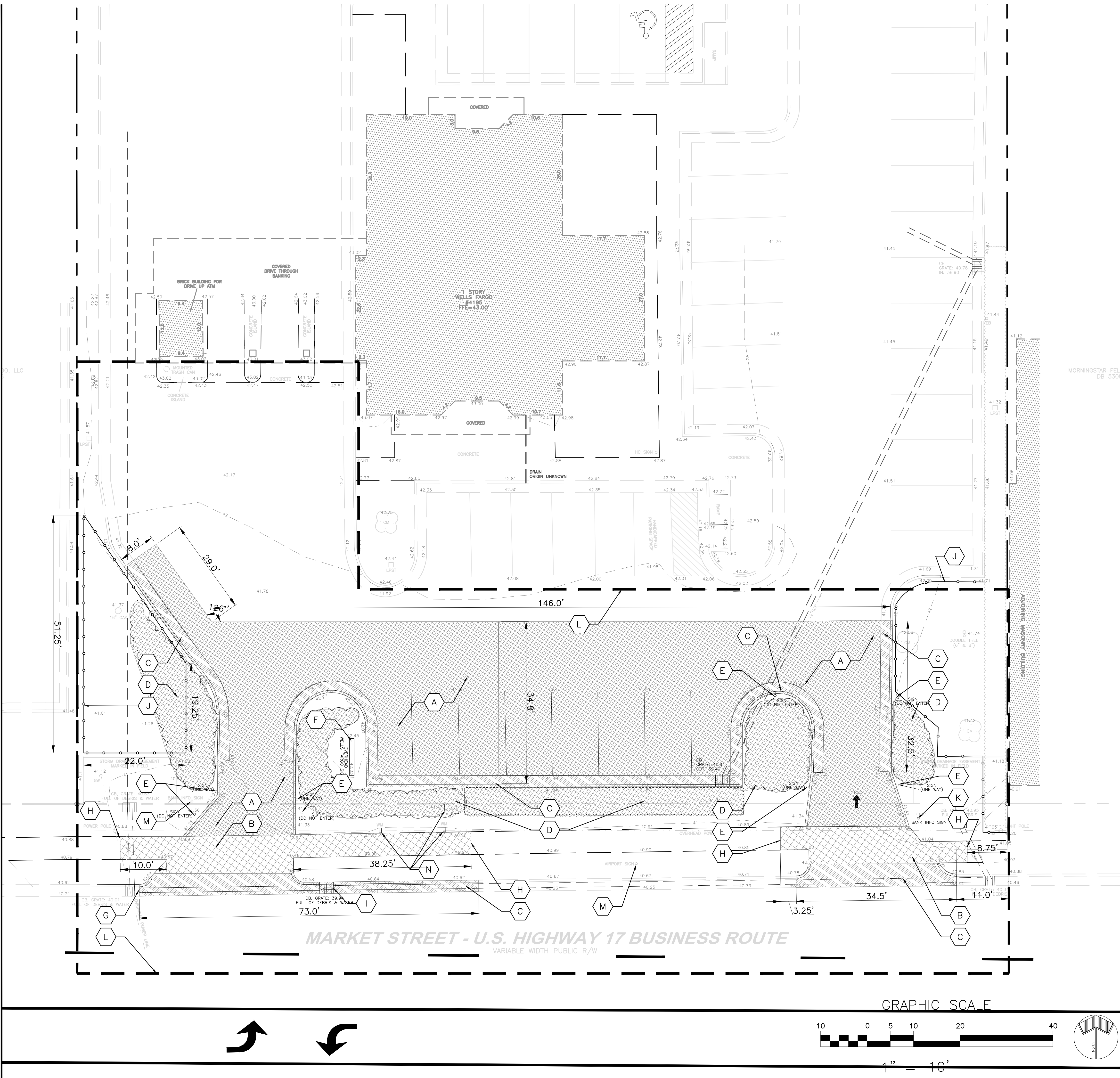

- DEMOLITION NOTES:**
- A. SAWCUT AND REMOVE EXISTING PAVEMENT. COORDINATE PAVEMENT CUTS WITH LAYOUT PLAN C3.00.
  - B. SAWCUT AND REMOVE EXISTING CONCRETE SIDEWALK. COORDINATE LIMITS WITH LAYOUT PLAN C3.00.
  - C. SAWCUT AND REMOVE EXISTING CURB AND GUTTER AND APRON. COORDINATE LIMITS WITH LAYOUT PLAN C3.00.
  - D. REMOVE EXISTING SHRUBS
  - E. REMOVE EXISTING SIGNAGE
  - F. RELOCATE EXISTING POLE SIGN. SEE SITE LAYOUT PLAN FOR NEW LOCATION.
  - G. TERMINATE CURB & GUTTER DEMOLITION AT EDGE OF EXISTING CURB INLET AS ILLUSTRATED. CONTRACTOR RESPONSIBLE FOR PROTECTING EXISTING INLET.
  - H. TERMINATE SIDEWALK DEMOLITION AT AN EXISTING SCORE JOINT.
  - I. CONVERT EXISTING CURB INLET TO JUNCTION BOX- SEE GRADING AND EROSION CONTROL PLAN. C4.00
  - J. TREE PROTECTION FENCE. SEE DETAIL 5015-09/C5.00.
  - K. RELOCATE EXISTING "BANK INFORMATION SIGN" PER SITE LAYOUT PLAN.
  - L. LIMITS OF CONSTRUCTION. (19555.23 SF)
  - M. EXISTING SIGN TO REMAIN AND BE PROTECTED
  - N. EXISTING WATER METER BOXES AND BACKFLOW PREVENTER TO REMAIN. ADJUST BOXES TO NEW ELEVATIONS AS NECESSARY.

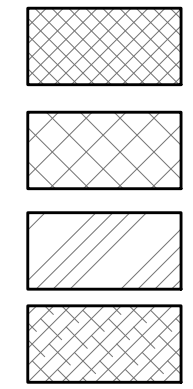

**LITTLE**  
DIVERSIFIED ARCHITECTURAL CONSULTING

5815 Westpark Drive Charlotte, NC 28217  
T: 704.525.6350 F: 704.561.8700  
www.littleonline.com

*This drawing and the design shown are the property of Little Diversified Architectural Consulting. The reproduction, copying or other use of this drawing without their written consent is prohibited and any infringement will be subject to legal action.*

© Little 2014

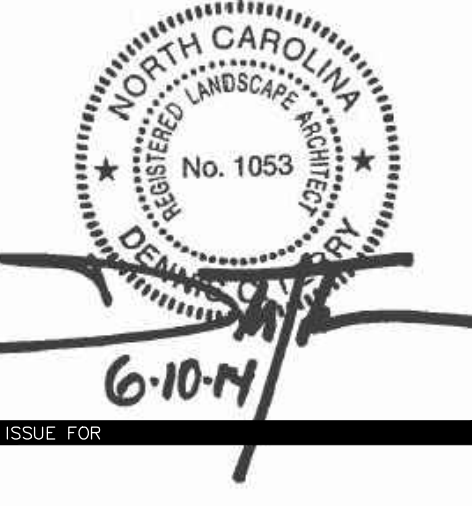
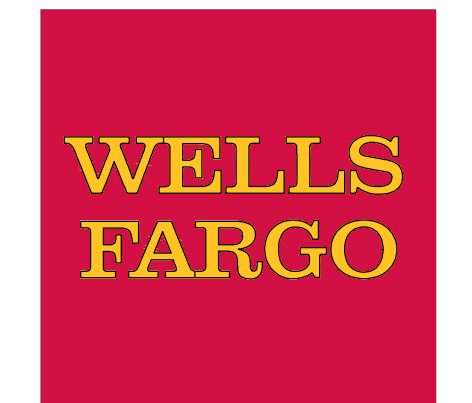

NO.	REVISIONS	DATE
01	06/06/2014 PRICING DOCUMENTS	
02	06/09/2014 PLANNING SUBMITTAL	
03	07/11/2014 PLANNING RE-SUBMITTAL	
04	07/11/2014 NCDOT RE-SUBMITTAL	
05	07/28/2014 PLANNING RE-SUBMITTAL	
06	07/28/2014 NCDOT RE-SUBMITTAL	

PROJECT TEAM  
PRINCIPAL IN CHARGE: Nancy Everhart, AIA, LEED AP  
PROJECT MANAGER: Dennis C. Terry, RLA  
DESIGN TEAM:

PROJECT NAME:  
**WELLS FARGO**  
4195 MARKET ST.  
WILMINGTON, NC

PROJECT NUMBER:  
123.2814.00  
SHEET TITLE:  
DEMOLITION PLAN

SHEET NUMBER:  
**C2.00**

**CAUTION!!!**  
The locations and elevations of existing underground utilities as shown on this drawing are only APPROXIMATE. No guarantee is either expressed or implied as to the completeness of accuracy thereof. The contractor shall be exclusively responsible for determining the exact utility locations and elevations prior to the start of construction

**WILMINGTON**  
NORTH CAROLINA  
Public Services • Engineering Division  
APPROVED PLAN - NO PERMIT REQUIRED  
Signed: \_\_\_\_\_

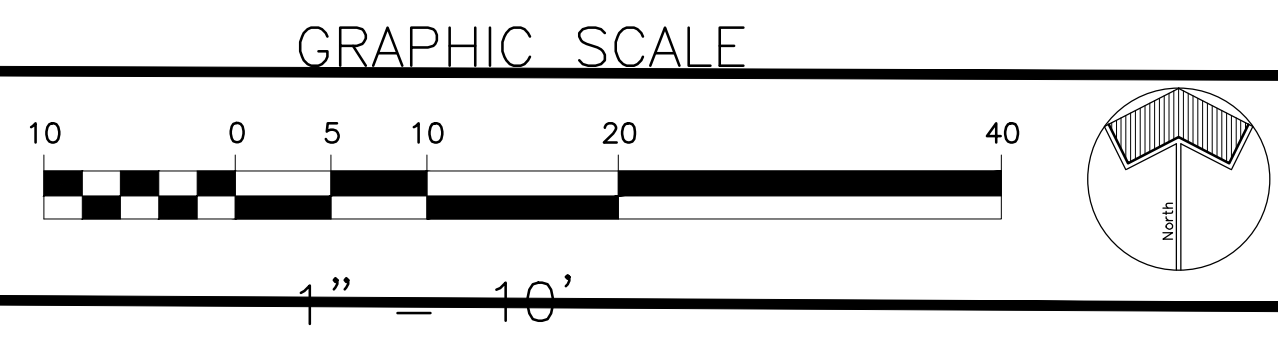



**PARKING SUMMARY:**

EXISTING PARKING	=	49
EXISTING PARKING SPACES	=	3
EXISTING ACCESSIBLE SPACES	=	52
TOTAL EXISTING SPACES	=	52
EXISTING SPACES TO BE DEMOLISHED	=	2
TOTAL SPACES FOLLOWING DEMOLITION	=	50
PROPOSED PARKING	=	2
PROPOSED PARKING SPACES	=	0
PROPOSED ACCESSIBLE SPACES	=	2
TOTAL PROPOSED SPACES	=	2
TOTAL PARKING	=	52 (NO NET GAIN OR LOSS)
TOTAL BICYCLE PARKING	=	5 TOTAL BIKE RACKS

**IMPERVIOUS AREA:**

EXISTING IMPERVIOUS	=	48,613 S.F.
EXISTING SITE AREA	=	11,787 S.F.
EXISTING LANDSCAPE AREA	=	36,826 S.F.
PROPOSED IMPERVIOUS	=	839 S.F.
EXISTING IMPERVIOUS AREA DEMOLISHED	=	540 S.F.
EXISTING IMPERVIOUS AREA INSTALLED	=	-299 S.F.

**SITE DATA TABLE:**

ZONING:	O&I
CAMA LAND USE CLASSIFICATION:	DEVELOPED

**CITY OF WILMINGTON STANDARD NOTES:**

- PRIOR TO ANY CLEARING, GRADING OR CONSTRUCTION, TREE PROTECTION FENCING SHALL BE INSTALLED AROUND PROTECTED TREES OR GROVES OF TREES. NO CONSTRUCTION WORKERS, TOOLS, MATERIALS, OR VEHICLES ARE PERMITTED WITHIN THE TREE PROTECTION FENCING.
- ANY TREES AND/OR AREAS DESIGNATED TO BE PROTECTED MUST BE PROPERLY BARRICADED WITH FENCING AND PROTECTED THROUGHOUT CONSTRUCTION TO INSURE THAT NO CLEARING, GRADING OR STAGING OF MATERIALS WILL OCCUR IN THOSE AREAS.
- NO EQUIPMENT IS ALLOWED ON SITE UNTIL ALL TREE PROTECTION FENCING AND SILT FENCING IS INSTALLED AND APPROVED. PROTECTIVE FENCING IS TO BE MAINTAINED THROUGHOUT THE DURATION OF THE PROJECT, AND CONTRACTORS SHALL RECEIVE ADEQUATE INSTRUCTION ON TREE PROTECTION METHODS.
- ALL PAVEMENT MARKINGS IN PUBLIC RIGHTS-OF-WAY AND FOR DRIVEWAYS ARE TO BE THERMOPLASTIC AND MEET CITY/NC DOT STANDARDS.
- ONCE STREETS ARE OPEN TO TRAFFIC, CONTACT TRAFFIC ENGINEERING REGARDING THE INSTALLATION OF TRAFFIC AND STREET NAME SIGNS. PROPOSED STREET NAMES MUST BE APPROVED PRIOR TO INSTALLATION OF STREET NAME SIGNS.
- TRAFFIC CONTROL DEVICES (INCLUDING SIGNS AND PAVEMENT MARKINGS) IN AREAS OPEN TO PUBLIC TRAFFIC ARE TO MEET MUTCD (MANUAL ON UNIFORM TRAFFIC CONTROL DEVICES) STANDARDS.
- CONTACT TRAFFIC ENGINEERING AT 910-341-7888 TO ENSURE THAT ALL TRAFFIC SIGNAL FACILITIES AND EQUIPMENT ARE SHOWN ON THE PLAN.
- CALL TRAFFIC ENGINEERING AT 910-341-7888 FORTY-EIGHT (48) HOURS PRIOR TO ANY EXCAVATION IN THE RIGHT-OF-WAY.
- TRAFFIC ENGINEERING MUST APPROVE OF PAVEMENT MARKING PRIOR TO ACTUAL STRIPING.
- ALL PARKING STALL MARKINGS AND LANE ARROWS WITHIN THE PARKING AREAS SHALL BE WHITE.
- ALL TRAFFIC CONTROL SIGNS AND MARKINGS OFF THE RIGHT-OF-WAY ARE TO BE MAINTAINED BY THE PROPERTY OWNER.
- STOP SIGNS AND STREET SIGNS TO REMAIN IN PLACE DURING CONSTRUCTION.
- TACTILE WARNING MATS WILL BE INSTALLED ON ALL WHEELCHAIR RAMPS.
- A UTILITY CUT PERMIT IS REQUIRED FOR EACH OPEN CUT OF A CITY STREET.
- ANY BROKEN OR MISSING SIDEWALK PANELS WILL BE REPLACED.
- CONTACT KAREN DIXON AT 910-341-7888 TO DISCUSS STREET LIGHTING OPTIONS.
- WATER AND SEWER SERVICE SHALL MEET CAPE FEAR PUBLIC UTILITY AUTHORITY (CFPUA) DETAILS AND SPECIFICATIONS.
- PROJECT SHALL COMPLY WITH CFPUA CROSS CONNECTION CONTROL REQUIREMENTS. WATER METER(S) CANNOT BE RELEASED UNTIL ALL REQUIREMENTS ARE MET AND THE STATE HAS GIVEN THEIR FINAL APPROVAL. CALL 910-343-3910 FOR INFORMATION.
- IF THE CONTRACTOR DESIRES CFPUA WATER FOR CONSTRUCTION, HE SHALL APPLY FOR THIS SERVICE AND MUST PROVIDE A REDUCED PRESSURE ZONE (RPZ) BACKFLOW PREVENTION DEVICE ON THE DEVELOPER'S SIDE OF THE WATER METER BOX.
- ANY IRRIGATION SYSTEM SUPPLIED BY CFPUA WATER SHALL COMPLY WITH THE CFPUA CROSS CONNECTION CONTROL REGULATIONS. CALL 919-343-3910 FOR INFORMATION.
- ANY IRRIGATION SYSTEM SHALL BE EQUIPPED WITH A RAIN AND FREEZER SENSOR.
- ANY BACKFLOW PREVENTION DEVICES REQUIRED BY THE CFPUA WILL NEED TO BE ON THE LIST OF APPROVED DEVICES BY USCFCOCHR OR ASSE.
- CONTRACTOR TO FIELD VERIFY EXISTING WATER AND SEWER SERVICE LOCATIONS, SIZES AND MATERIALS PRIOR TO CONSTRUCTION. ENGINEER TO BE NOTIFIED OF ANY CONFLICTS.
- CONTRACTOR SHALL MAINTAIN ALL-WEATHER ACCESS FOR EMERGENCY VEHICLES AT ALL TIMES DURING CONSTRUCTION.
- UNDERGROUND FIRE LINE(S) MUST BE PERMITTED AND INSPECTED BY THE WILMINGTON FIRE DEPARTMENT FROM THE PUBLIC RIGHT-OF-WAY TO THE BUILDING. CONTACT THE WILMINGTON FIRE DEPARTMENT DIVISION OF FIRE AND LIFE SAFETY AT 910-341-0896.
- NO OBSTRUCTIONS ARE PERMITTED IN THE SPACE BETWEEN THIRTY (30) INCHES AND TEN (10) FEET ABOVE THE GROUND WITHIN THE TRIANGULAR SIGHT DISTANCE.
- CONTACT THE NORTH CAROLINA ONE CALL CENTER AT 1-800-632-4949 PRIOR TO DOING ANY DIGGING, CLEARING, OR GRADING

**LAYOUT NOTES:**

- NC DOT STANDARD CONCRETE SIDEWALK. SEE DETAIL SD 3-10/C5.00.
- CITY OF WILMINGTON STANDARD 2'-6" CURB AND GUTTER. SEE DETAIL SD 3-11/C5.00.
- "RIGHT TURN ONLY" SIGN. SEE GENERAL NOTE A.
- 4" WIDE PAINTED PARKING STRIPES. (WHITE) ALL DIMENSIONS ARE TO CENTER OF 4" PARKING STRIPE
- LIMITS OF 2'-6" CURB & GUTTER TO MEET FLUSH WITH EXISTING.
- CONVERT EXISTING CURB INLET TO JUNCTION BOX. SEE GRADING PLAN.
- "ONE WAY" SIGN. SEE GENERAL NOTE A.
- LIGHT DUTY ASPHALT PAVING. SEE DETAIL 1/C5.00.
- PAINTED DIRECTIONAL ARROW (WHITE THERMOPLASTIC PER NC DOT - SEE GENERAL NOTE A). SEE GENERAL NOTE A & DETAIL 2/C5.00.
- 6" WIDE PAINTED LANE STRIPING (WHITE THERMOPLASTIC PER NC DOT - SEE GENERAL NOTE A) (4" DIAGONAL STRIPING (WHERE ILLUSTRATED). ALL DIMENSIONS ARE TO THE CENTER OF 6" PAINT STRIPE.
- NEW CONCRETE SIDEWALK TO MEET FLUSH WITH EXISTING.
- RELOCATED SIGN. COORDINATE WITH DEMOLITION PLAN. CITY OF WILMINGTON SIGNAGE PERMIT TO BE OBTAINED BY CONTRACTOR. PLEASE CONTACT 910-254-0900. SEE DETAIL 7/C5.00.
- CITY OF WILMINGTON STANDARD DRIVEWAY APRON. SEE DETAIL SD 8-02/C5.00.
- CITY OF WILMINGTON VERTICAL CURB. SEE DETAIL SD 3-11/C5.00.
- 24" WIDE PAINTED STOP BAR AND 18" HIGH PAINTED LETTERS "DO NOT ENTER". (WHITE).
- 20'X70' CITY OF WILMINGTON SIGHT TRIANGLE. ALL PROPOSED VEGETATION WITHIN SIGHT TRIANGLE SHALL NOT INTERFERE WITH CLEAR VISUAL SIGHT LINES FROM 30"-10'.
- 18" WIDE PAINTED CROSSWALK STRIPING (WHITE). ALL DIMENSIONS ARE TO THE CENTER OF THE 18" PAINT STRIPE.
- DASHED LINE INDICATES ACCESSIBLE FLUSH CURB AND GUTTER. SEE DETAIL 5/C5.00.
- TRUNCATED DOME MAT - SEE DETAIL 6/C5.00.
- 3' CURB TAPER. SEE DETAIL 8/C5.00.
- ACCESSIBLE ROUTE - CONTRACTOR TO ENSURE THAT RUNNING SLOPE IS NOT GREATER THAN 5% AND THAT THE CROSS SLOPE IS NOT MORE THAN 2% ALONG THIS ROUTE; WHERE ROUTE EXCEEDS 5%, INSTALL HANDRAIL AS SHOWN.
- BIKE RACK. FIVE TOTAL. SEE DETAIL 9/C5.00.
- CITY OF WILMINGTON STANDARD VALLEY CURB. SEE DETAIL SD 3011/C5.00.
- 10'X70' NC DOT SIGHT TRIANGLE.

**GENERAL NOTES:**

- THE UTILITIES AND THE LOCATION THEREOF, SHOWN ON THE DRAWINGS, REPRESENT THE DESIGNERS UNDERSTANDING OF EXISTING UTILITIES IN THE CONSTRUCTION AREA. THE CONTRACTOR SHALL FIELD VERIFY THE LOCATION, DEPTH AND EXISTENCE OF ALL UTILITIES (ELECTRICAL, MECHANICAL, WATER, TELEPHONE, GAS ETC.) WITHIN THE CONSTRUCTION AREA WITH THE OWNER AND/OR THE APPROPRIATE UTILITY COMPANY PRIOR TO ANY EXCAVATION. THE OMISSION OF OR THE INCLUSION OF UTILITY LOCATIONS ON THE PLANS IS NOT TO BE CONSIDERED AS THE EXISTENCE OF OR A DEFINITE LOCATION. UTILITIES SHALL BE REPAIRED AT THE CONTRACTOR'S EXPENSE. CONTACT U-LOCO (1-800-632-4949) PRIOR TO DIGGING.
- ALL PAVING CUTS SHALL BE MADE BY SAW CUTS. EXISTING ELEVATIONS SHALL BE FIELD VERIFIED AND MATCHED.
- CONTRACTOR TO COORDINATE ANY CHANGES IN FIELD CONDITIONS THAT MAY REVISE THE DESIGN WITH ARCHITECT / ENGINEER PRIOR TO PROCEEDING.
- ANY UNSUITABLE MATERIAL ON SITE IS TO BE QUANTIFIED BY A GEOTECHNICAL ENGINEER, PRIOR TO REMOVING. CONTRACTOR MUST NOTIFY OWNER, OR OWNER'S REPRESENTATIVE IN CASE UNSUITABLE MATERIAL IS UNCOVERED.
- NEW CONCRETE SIDEWALKS SHALL BE 4" THICK, 3000 PSI PORTLAND CEMENT CONCRETE OVER COMPACTED SUBGRADE WITH 1" DEEP (1/8" RADI) GROOVE JOINTS (C.J.) AND 1/2" EXPANSION JOINTS ( ) AT INTERVALS INDICATED ON THE PLAN AND ABUTTING ALL RIGID STRUCTURES. IN NO CASES SHALL EXP-JT. SPACING EXCEED 30'-0".
- ALL DIMENSIONS ARE TO FACE OF CURB OR TO FINISHED FACE OF BUILDING UNLESS NOTED OTHERWISE.
- ALL RADII ON CURBS SHALL BE 5'-0" UNLESS NOTED OTHERWISE.
- ANY BROKEN OR MISSING SIDEWALK PANELS, DRIVEWAY PANELS AND CURBING WILL BE REPLACED.

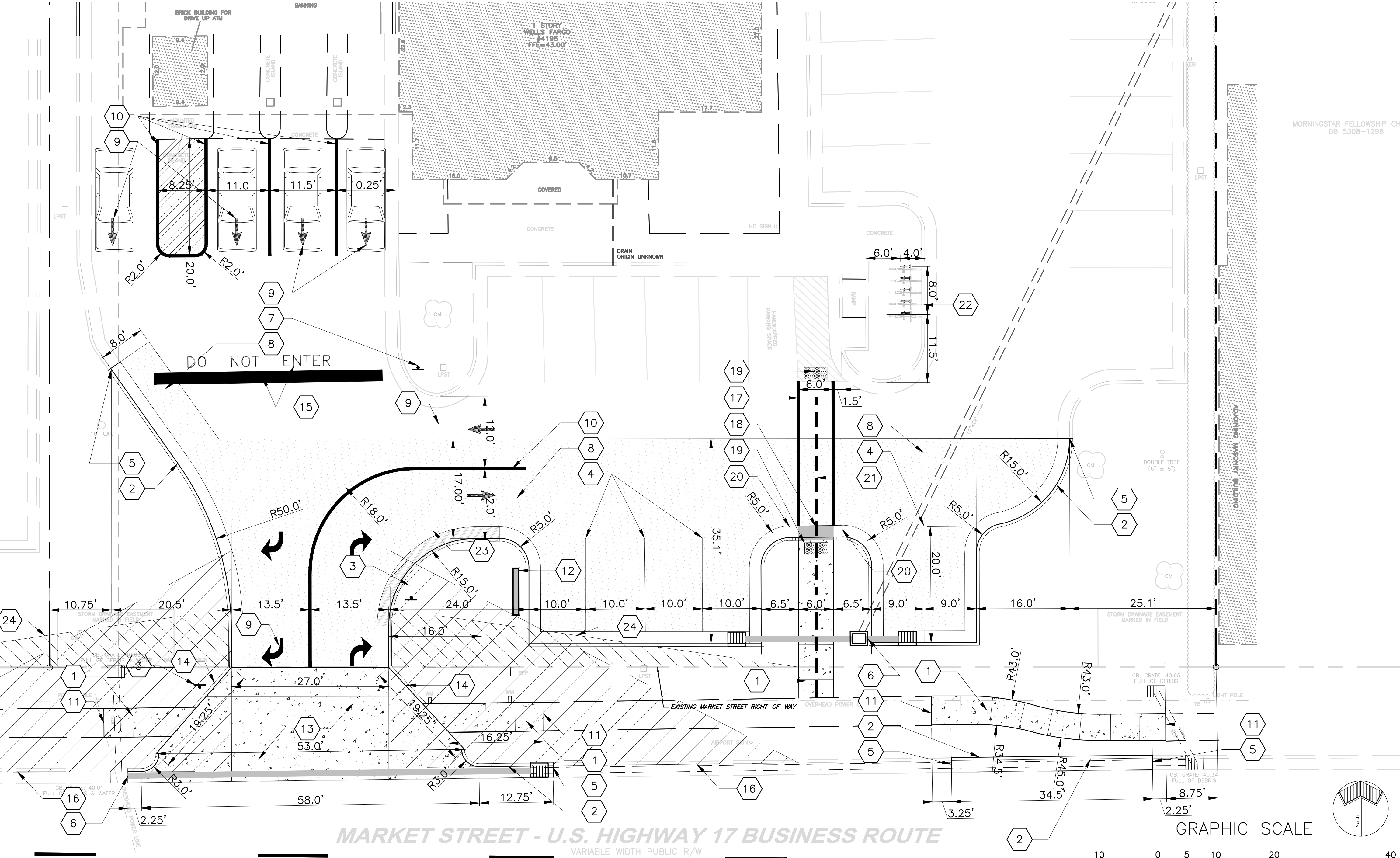

5815 Westpark Drive Charlotte, NC 28217  
 T: 704.525.6350 F: 704.561.8700  
 www.littleonline.com

*This drawing and the design shown are the property of Little Diversified Architectural Consulting. The reproduction, copying or other use of this drawing without their written consent is prohibited and any infringement will be subject to legal action.*

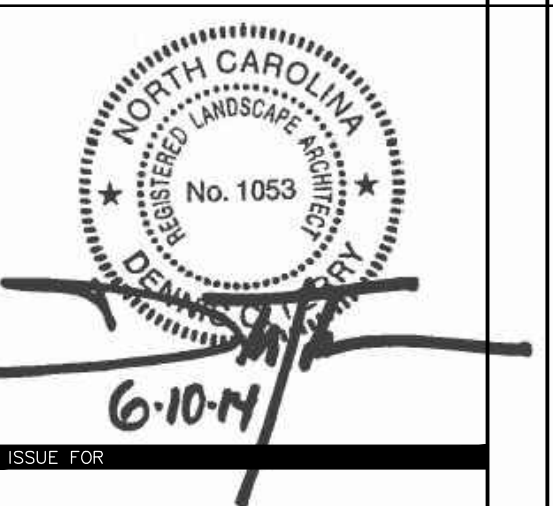
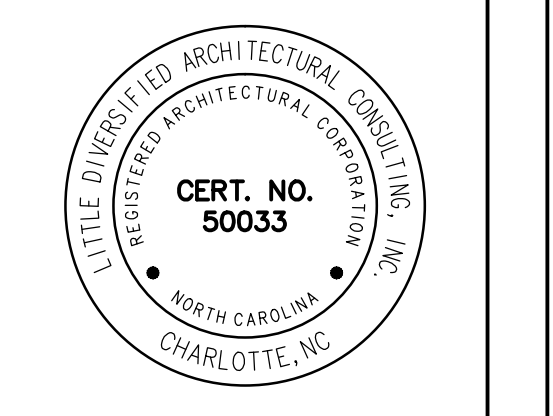

ISSUE FOR: 6-10-14

ISSUE DATE	REVISIONS
06 JUNE 2014	
01	06/06/2014 PRICING DOCUMENTS
02	06/09/2014 PLANNING SUBMITTAL
03	07/11/2014 PLANNING RE-SUBMITTAL
04	07/11/2014 NC DOT RE-SUBMITTAL

PROJECT LEAD: Nancy Everhart, AIA, LEED AP  
 PROJECT MANAGER: Dennis C. Terry, RLA  
 DESIGN TEAM: WELLS FARGO  
 4195 MARKET ST.  
 WILMINGTON, NC

PROJECT NUMBER: 123.2814.00  
 SHEET TITLE: SITE LAYOUT PLAN

SHEET NUMBER: C3.00

**WILMINGTON** NORTH CAROLINA  
 Public Services • Engineering Division  
 APPROVED PLAN - NO PERMIT REQUIRED  
 Signed: \_\_\_\_\_

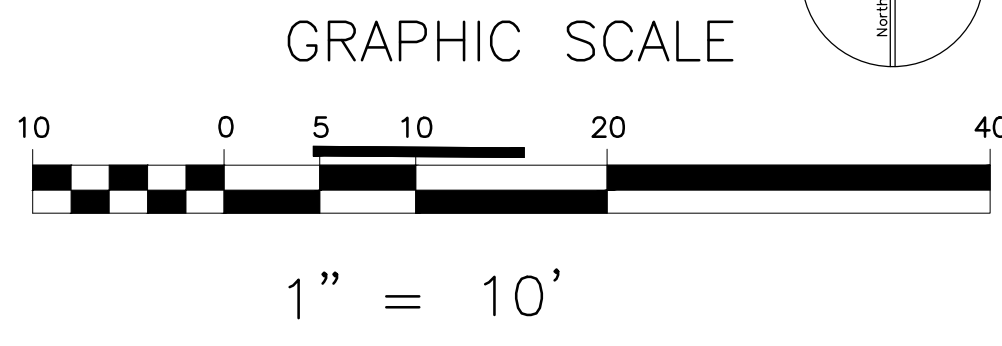

F:\SDS\Site\Civil\101-2814-00 Wilmington Wells Fargo\Site\CD's\C3.00 Site Layout Plan.dwg Jul 30, 2014-12:06pm



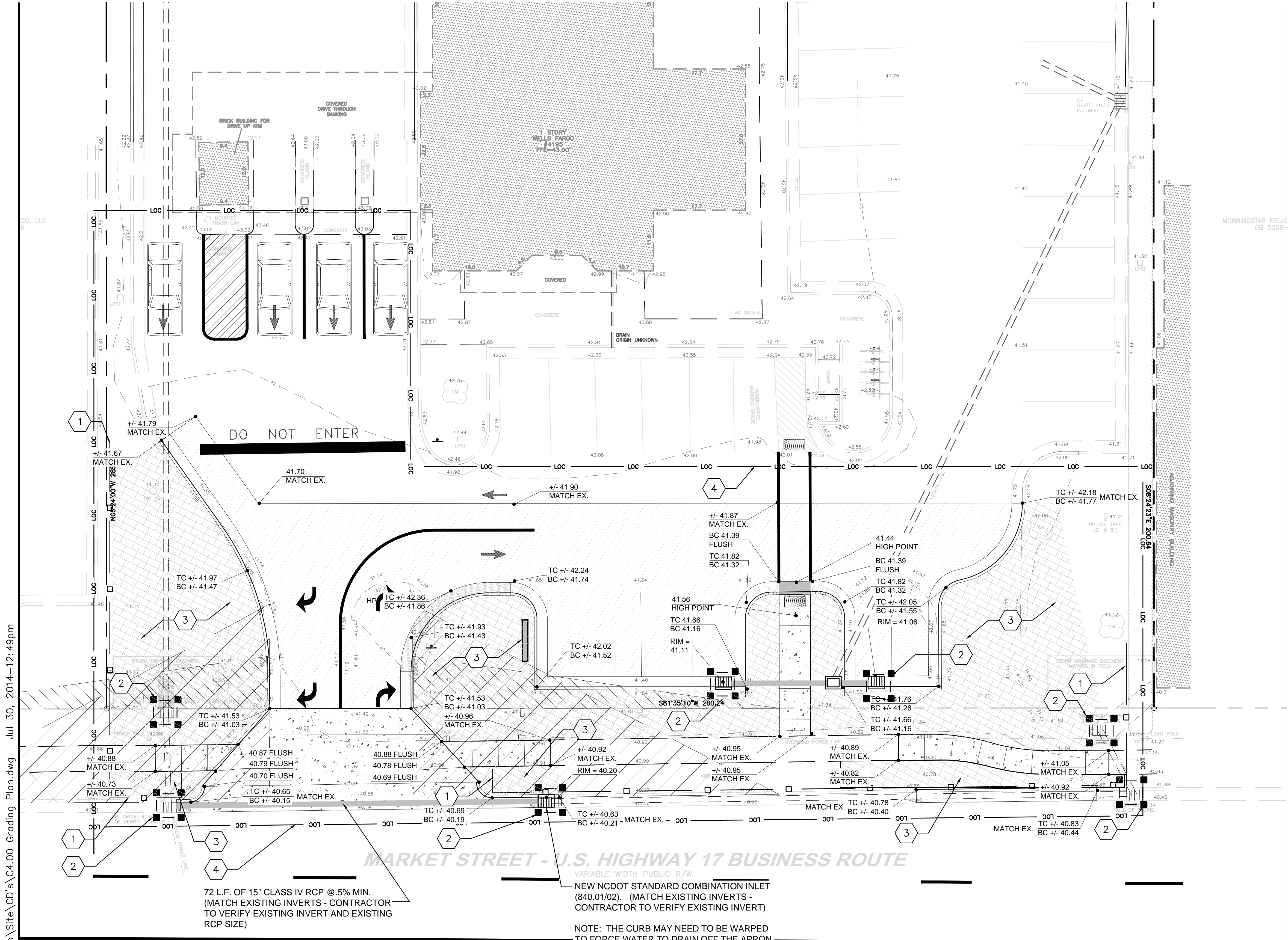

**GRADING NOTES:**

1. VERIFY ALL EXISTING GRADES. REPORT ANY DISCREPANCIES TO ARCHITECT.
2. ALL NEW CONTOURS AND SPOT ELEVATIONS ARE SHOWN AS FINISHED GRADES. THE GRADING CONTRACTOR MUST MAKE ALLOWANCES FOR THICKNESS OF PAVING SECTIONS, CONCRETE SLABS, ETC. WHERE APPLICABLE.
3. THE ENTIRE SITE WITHIN THE LIMIT OF CONSTRUCTION SHALL BE GRADED TO DRAIN FREELY. ALL UNPAVED AREAS DISTURBED BY CONSTRUCTION, WHETHER INSIDE OR OUTSIDE OF THE LIMIT OF CONSTRUCTION, SHALL BE FINE GRADED AND SEEDED TO ESTABLISH A PERMANENT LAWN.
4. CONTRACTOR SHALL PROTECT ALL EXISTING UTILITIES (INCLUDING SANITARY, STORM DRAINAGE, AND WATER) FROM DAMAGE DURING CONSTRUCTION. ALL UNDERGROUND UTILITIES EXPOSED DURING CONSTRUCTION OR THOSE LEFT WITH LESS THAN ACCEPTABLE MINIMUM EARTH COVER SHALL BE RELOCATED AS DETERMINED BY THE ARCHITECT.
5. NO SLOPES SHALL BE GRADED STEEPER THAN 3:1, UNLESS INDICATED OTHERWISE.
6. ANY GRADING BEYOND THE PROPERTY LINE INDICATED ON THE CONSTRUCTION DOCUMENTS IS A VIOLATION AND IS SUBJECT TO A FINE.
7. GRADING MORE THAN ONE ACRE WITHOUT AN APPROVED EROSION CONTROL PLAN IS A VIOLATION AND IS SUBJECT TO A FINE.
8. APPROVAL OF THIS PLAN IS NOT AN AUTHORIZATION TO GRADE ADJACENT PROPERTIES. WHEN FIELD CONDITIONS WARRANT OFF-SITE GRADING, PERMISSION MUST BE OBTAINED FROM THE AFFECTED PROPERTY OWNERS.
9. THE UTILITIES AND THE LOCATION THEREOF, SHOWN ON THE DRAWINGS, REPRESENT THE DESIGNER'S UNDERSTANDING OF EXISTING UTILITIES IN THE CONSTRUCTION AREA. THE CONTRACTOR SHALL FIELD VERIFY THE LOCATION, DEPTH AND EXISTENCE OF ALL UTILITIES (ELECTRICAL, MECHANICAL, WATER, TELEPHONE, GAS ETC.) WITHIN THE CONSTRUCTION AREA WITH THE OWNER AND/OR THE APPROPRIATE UTILITY COMPANY PRIOR TO ANY EXCAVATION. THE OMISSION OF OR THE INCLUSION OF UTILITY LOCATIONS ON THE PLANS IS NOT TO BE CONSIDERED AS THE NONEXISTENCE OF OR A DEFINITE LOCATION. UTILITIES SHALL BE REPAIRED AT THE CONTRACTOR'S EXPENSE. CONTACT U-LOCO (1-888-721-7877) PRIOR TO DIGGING.
10. CONTRACTOR TO COORDINATE ANY CHANGES IN FIELD CONDITIONS THAT MAY REVISE THE DESIGN WITH ARCHITECT / ENGINEER PRIOR TO PROCEEDING.
11. ANY UNSUITABLE MATERIAL ON SITE IS TO BE QUANTIFIED BY A GEOTECHNICAL ENGINEER, PRIOR TO REMOVING. CONTRACTOR MUST NOTIFY OWNER, OR OWNER'S REPRESENTATIVE IN CASE UNSUITABLE MATERIAL IS UNCOVERED.

**EROSION CONTROL/MAINTENANCE NOTES:**

- A. NO ON-SITE BURIAL PIT WILL BE LOCATED ON THIS SITE. CONTRACTOR RESPONSIBLE FOR PROPER DISPOSAL OF DEBRIS.
- B. ANY GRADING BEYOND THE DENUDED LIMITS SHOWN ON THE PLAN IS A VIOLATION OF THE STATE'S EROSION CONTROL ORDINANCE AND IS SUBJECT TO A FINE.
- C. GRADING MORE THAN ONE ACRE WITHOUT AN APPROVED EROSION CONTROL PLAN IS A VIOLATION OF THE STATE'S EROSION CONTROL ORDINANCE AND IS SUBJECT TO A FINE.
- D. ALL EROSION AND SEDIMENT CONTROL PRACTICES WILL BE CHECKED FOR STABILITY AND OPERATION FOLLOWING EVERY RUNOFF-PRODUCING RAINFALL BUT IN NO CASE LESS THAN ONCE EVERY WEEK. ANY NEEDED REPAIRS WILL BE MADE IMMEDIATELY TO MAINTAIN ALL PRACTICES AS DESIGNED. SEDIMENT WILL BE REMOVED FROM THE SEDIMENT TRAP AND INLET PROTECTION DEVICES WHEN STORAGE CAPACITY HAS BEEN APPROXIMATELY 50% FILLED. GRAVEL WILL BE CLEANED OR REPLACED WHEN THE SEDIMENT POOL NO LONGER DRAINS PROPERLY.
- E. SEDIMENT WILL BE REMOVED FROM BEHIND THE SEDIMENT FENCE WHEN IT BECOMES ABOUT 6" DEEP AT THE FENCE. THE SEDIMENT FENCE WILL BE REPAIRED AS NECESSARY TO MAINTAIN A BARRIER.
- F. PERMANENT GROUND COVER MUST BE ESTABLISHED WITHIN THE PROPOSED DITCHES AND CHANNELS. ADDITIONAL MECHANICAL MEASURES WILL BE REQUIRED IF VEGETATIVE COVER CAN NOT BE ESTABLISHED AS PROPOSED.
- G. PROVIDE STRAW EROSION CONTROL BLANKET WITH BIODEGRADABLE NETTING & 0.5 LBS/SQYD STRAW FIBER ON ALL SLOPES THAT ARE 3:1 OR STEEPER AND ARE NOT ALREADY SPECIFIED TO RECEIVE ANOTHER TYPE OF BLANKET.
- H. STABILIZATION IS THE BEST FORM OF EROSION CONTROL. TEMPORARY SEEDING IS NECESSARY TO ACHIEVE EROSION CONTROL ON LARGE DENUDED AREAS AND ESPECIALLY WHEN SPECIFICALLY REQUIRED AS PART OF THE CONSTRUCTION SEQUENCE SHOWN ON THE PLAN.
- I. ADDITIONAL MEASURES TO CONTROL EROSION AND SEDIMENT MAY BE REQUIRED BY A REPRESENTATIVE OF THE STATE.
- J. APPROVAL OF THIS PLAN IS NOT AN AUTHORIZATION TO GRADE ADJACENT PROPERTIES. WHEN FIELD CONDITIONS WARRANT OFF-SITE GRADING, PERMISSION MUST BE OBTAINED FROM THE AFFECTED PROPERTY OWNERS AND NCDENR.
- K. INLET PROTECTION IS REQUIRED FOR ALL INLETS LOCATED IN THE WORKING AREA AND REQUIRED UNTIL THE SITE IS FULLY STABILIZED.
- L. CONTRACTOR SHALL TAKE ALL REASONABLE MEASURES TO PREVENT TRACKING MUD/ SOIL ON ADJACENT ROADWAYS. ANY MUD/SOIL TRACKED ON ADJACENT ROADWAYS SHALL BE CLEANED DAILY BY THE CONTRACTOR.

**EROSION CONTROL LEGEND:**

1. SILT FENCE - SEE DETAIL 2/C5.01
2. BLOCK & GRAVEL INLET PROTECTION - SEE DETAIL 3/C5.01
3. TEMPORARY SEEDING - SEE DETAIL 5/C5.01
4. LIMITS OF CONSTRUCTION (DENUDED AREA = 0.17 ACRES)

72 L.F. OF 15" CLASS IV RCP @ 5% MIN. (MATCH EXISTING INVERTS - CONTRACTOR TO VERIFY EXISTING INVERT AND EXISTING RCP SIZE)

NEW NCDOT STANDARD COMBINATION INLET (840.01/02). (MATCH EXISTING INVERTS - CONTRACTOR TO VERIFY EXISTING INVERT)

NOTE: THE CURB MAY NEED TO BE WARPED TO FORCE WATER TO DRAIN OFF THE APRON TO THE INLET ON EITHER SIDE.

**CAUTION!!!**  
The locations and elevations of existing underground utilities as shown on this drawing are only APPROXIMATE. No guarantee is either expressed or implied as to the completeness of accuracy thereof. The contractor shall be exclusively responsible for determining the exact utility locations and elevations prior to the start of construction.

GRAPHIC SCALE

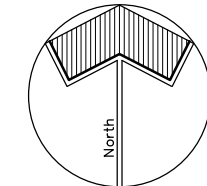
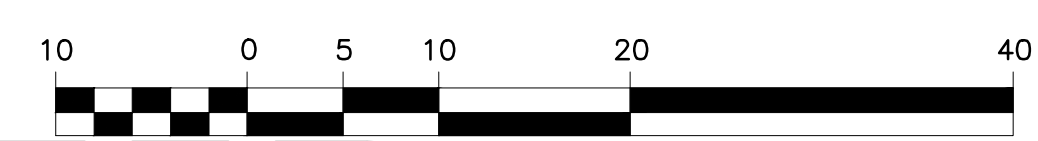

**WILMINGTON**  
NORTH CAROLINA  
Public Services • Engineering Division  
APPROVED PLAN - NO PERMIT REQUIRED  
Signed: \_\_\_\_\_

**LITTLE**  
DIVERSIFIED ARCHITECTURAL CONSULTING

5815 Westpark Drive Charlotte, NC 28217  
T: 704.525.6350 F: 704.561.8700

www.littleonline.com

This drawing and the design shown are the property of Little Diversified Architectural Consulting. The reproduction, copying or other use of this drawing without their written consent is prohibited and any infringement will be subject to legal action.

© Little 2014

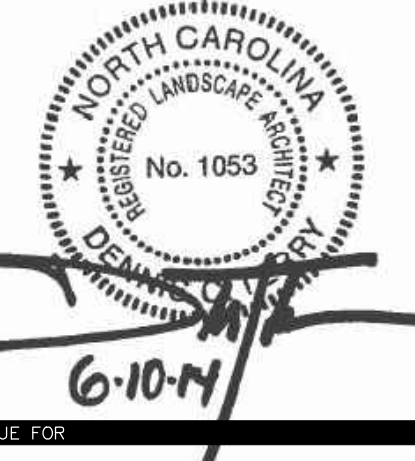

NO.	REVISIONS	DATE
01	06/06/2014 PRICING DOCUMENTS	
02	06/09/2014 PLANNING SUBMITTAL	
03	07/11/2014 PLANNING RE-SUBMITTAL	
04	07/11/2014 NCDOT RE-SUBMITTAL	
05	07/28/2014 PLANNING RE-SUBMITTAL	
06	07/28/2014 NCDOT RE-SUBMITTAL	

PROJECT TEAM  
PRINCIPAL IN CHARGE: Nancy Everhart, AIA, LEED AP  
PROJECT MANAGER: Dennis C. Terry, RLA  
DESIGN TEAM:

PROJECT NAME:  
**WELLS FARGO**  
4195 MARKET ST.  
WILMINGTON, NC

PROJECT NUMBER:  
123.2814.00

SHEET TITLE:  
GRADING AND EROSION CONTROL PLAN

SHEET NUMBER:  
**C4.00**

F:\SDS\SiteCiv\101-2814-00 Wilmington Wells Fargo\CD's\C4.00 Grading Plan.dwg Jul 30, 2014-12:49pm

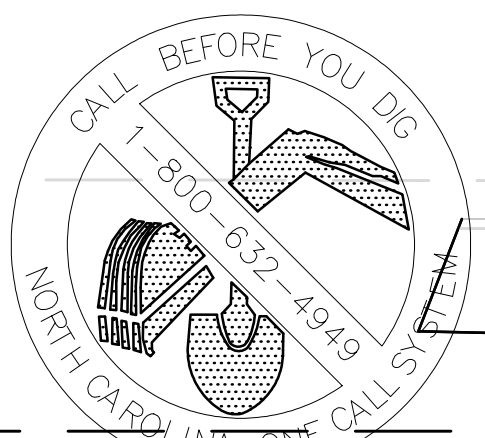



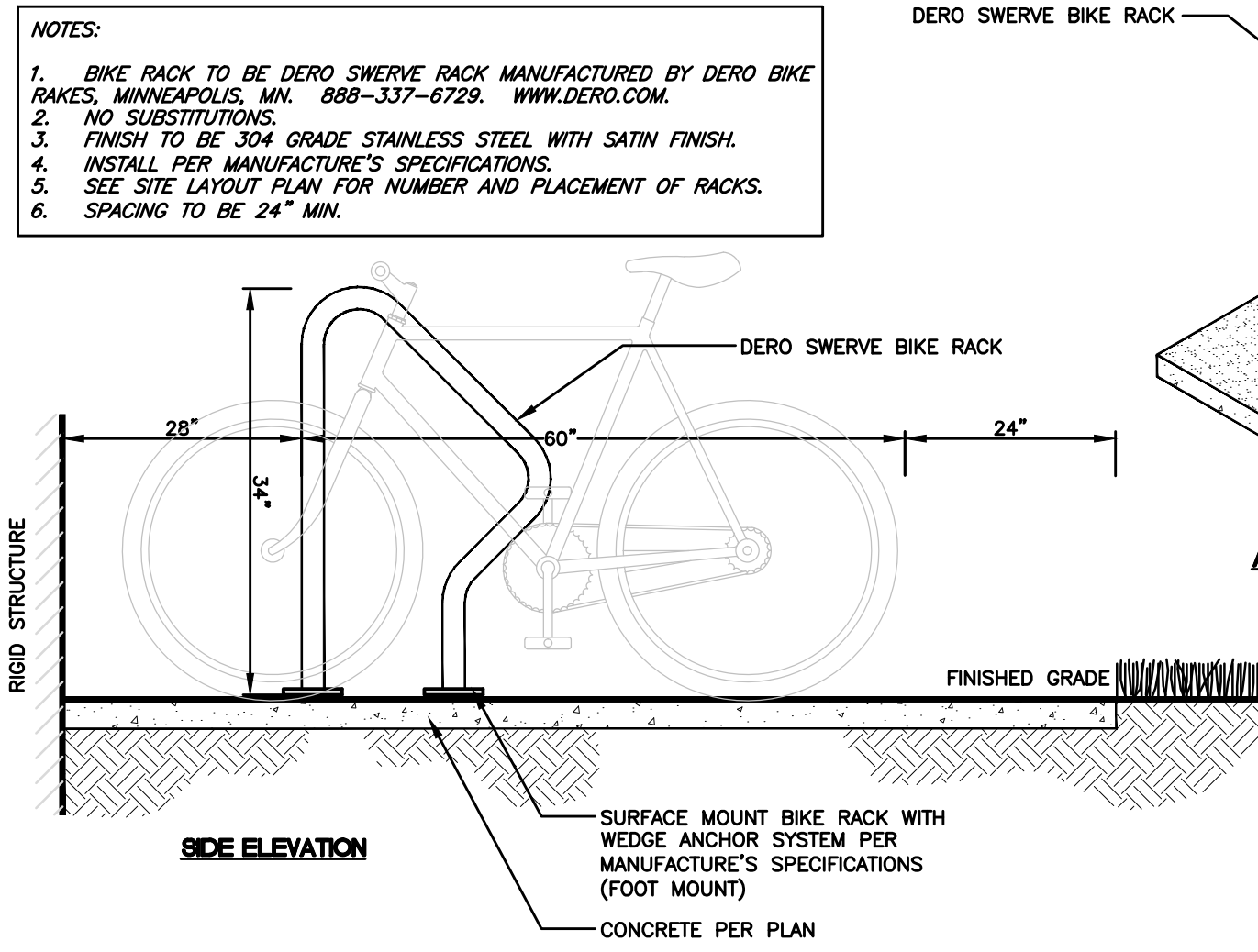

**9 BIKE RACK**  
NOT TO SCALE

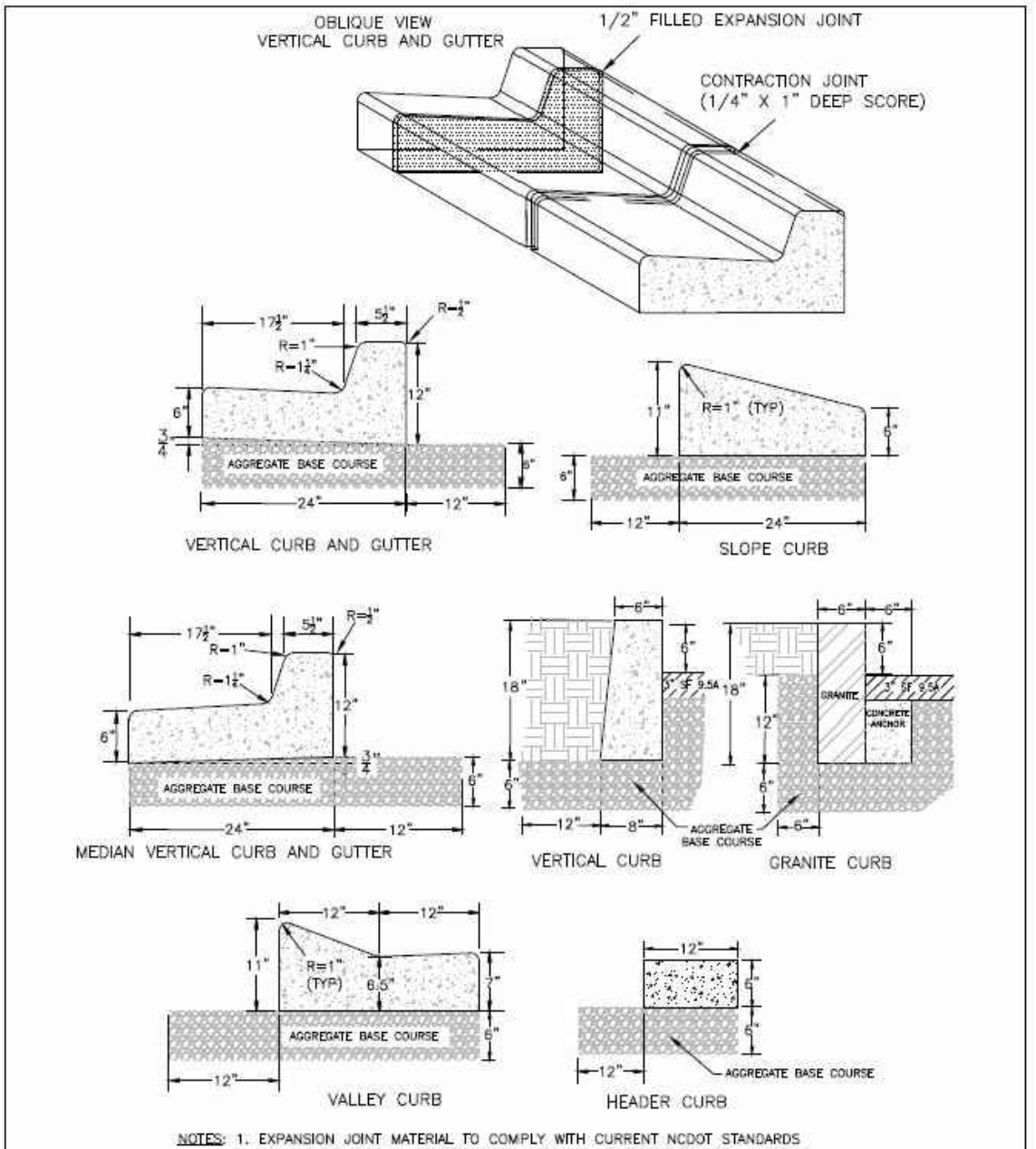
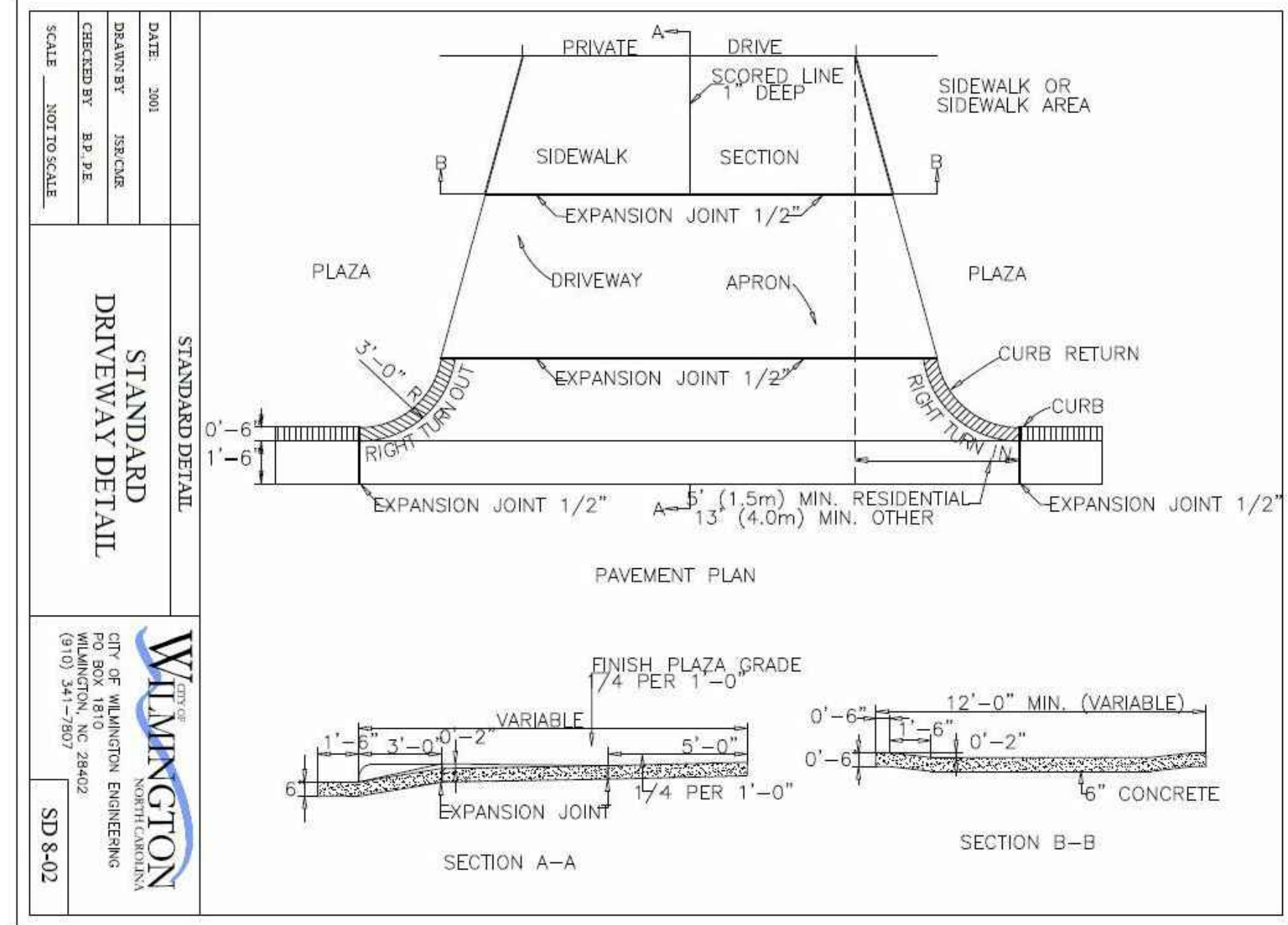

**STANDARD DETAIL  
CURBING**  
SD 3-11

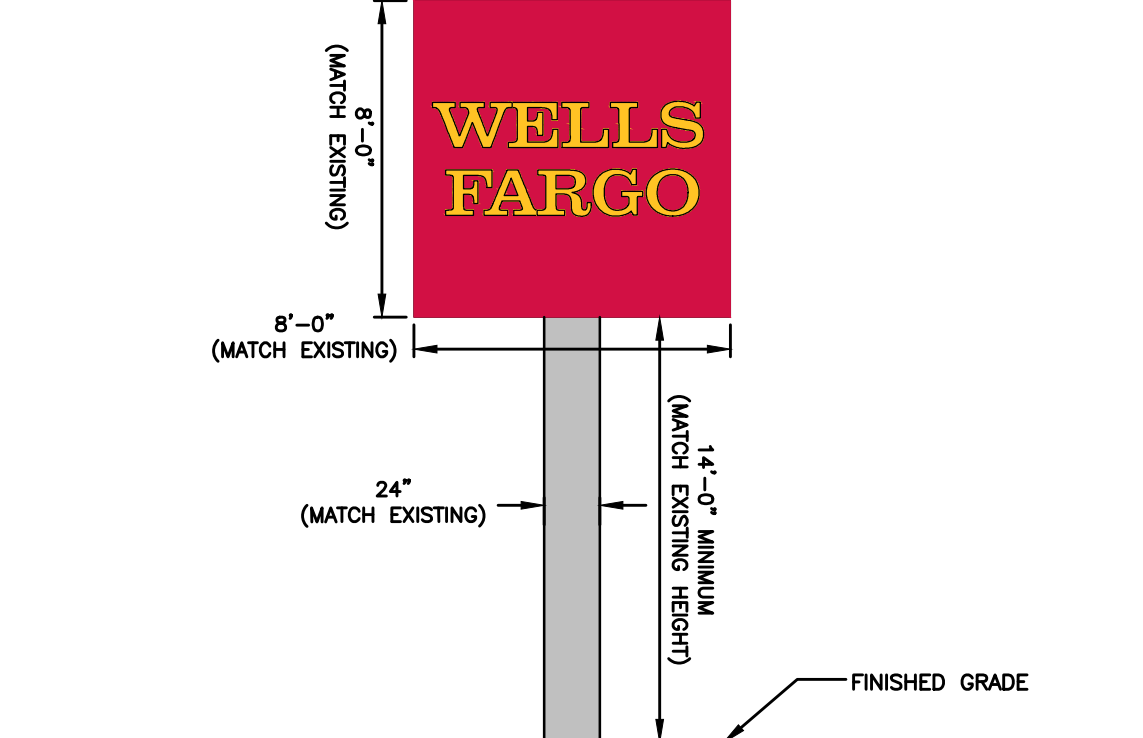
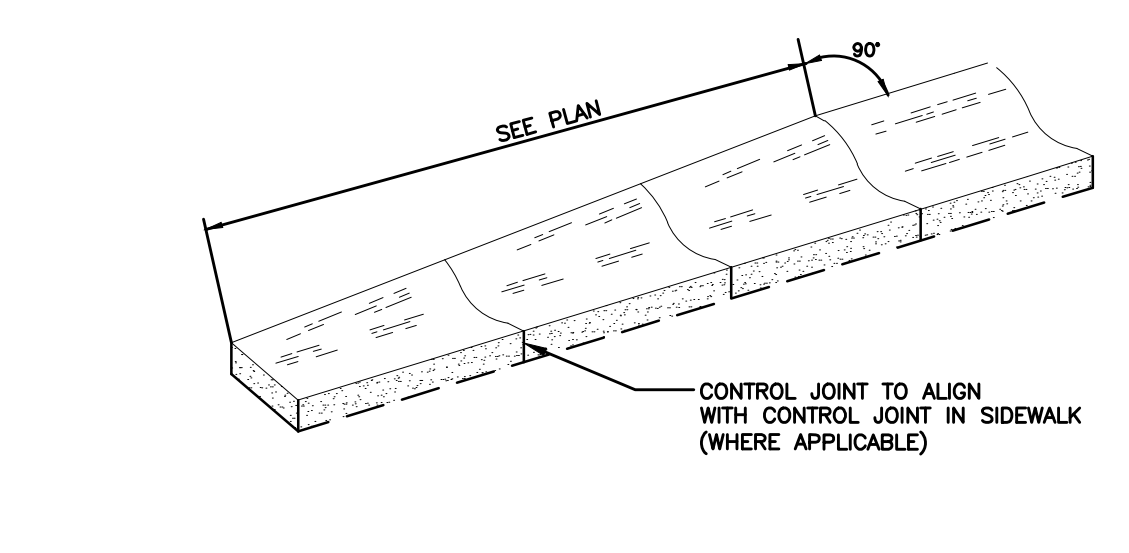

- NOTES:**
- ALL DETECTABLE WARNING DEVICES USED IN NEW CONSTRUCTION SHALL BE OF A RIGID PRECAST OR EMBEDDED PRODUCT APPROVED BY THE CITY ENGINEER. RETRO FIT MATS WILL ONLY BE ALLOWED ON EXISTING RAMPS WITH PRIOR APPROVAL OF THE CITY ENGINEER FOR MATERIAL TYPE AND INSTALLATION (I.E. RESURFACING).
  - WIDTH OF DETECTABLE WARNING AREA SHALL BE A MINIMUM OF 4 FEET AND VARY WITH WIDTH OF RAMP.
  - LENGTH OF DETECTABLE WARNING AREA SHALL BE 2 FEET REGARDLESS OF SECTION WIDTH.
  - DETECTABLE WARNING AREA CAN BE SQUARE WHERE USED IN A CURB RADIUS.
  - DETECTABLE WARNING DOMES SHALL BE ALIGNED ON A SQUARE GRID IN THE PREDOMINANT DIRECTION OF TRAVEL TO PERMIT WHEELS TO ROLL BETWEEN DOMES.
  - DETECTABLE WARNING AREA SHALL BE COLORED BLACK IN ALL LOCATIONS.
  - IF PAVERS ARE TO BE USED, PAVERS SHALL BE 6" THICK AND CAST FROM 5,000 PSI CONCRETE.
  - MATS ARE TO BE RIGID WITH TURN DOWN EDGES EMBEDDED IN CONCRETE TO ELIMINATE TRIP HAZARD.

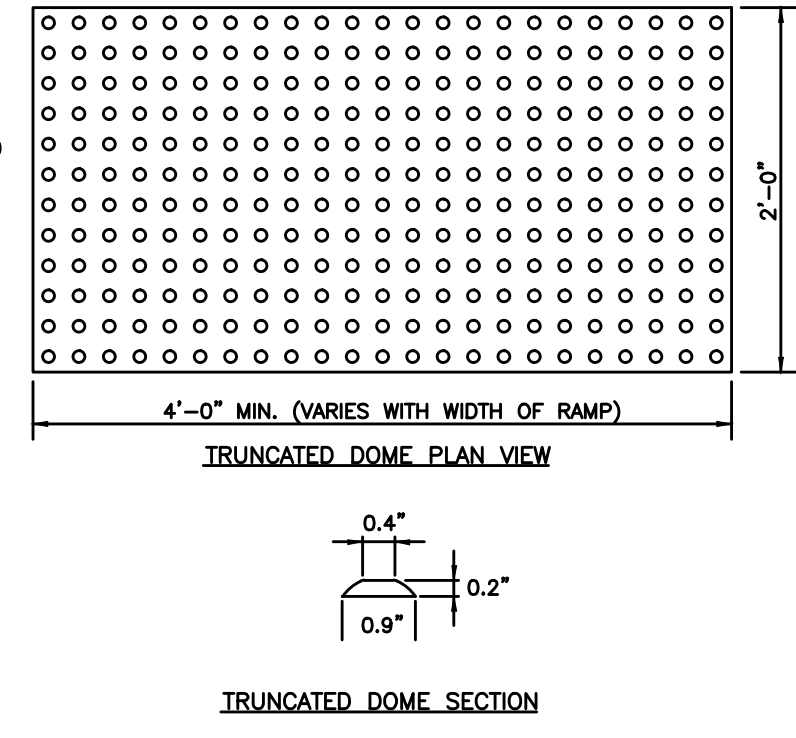

**6 TRUNCATED DOME**  
NOT TO SCALE

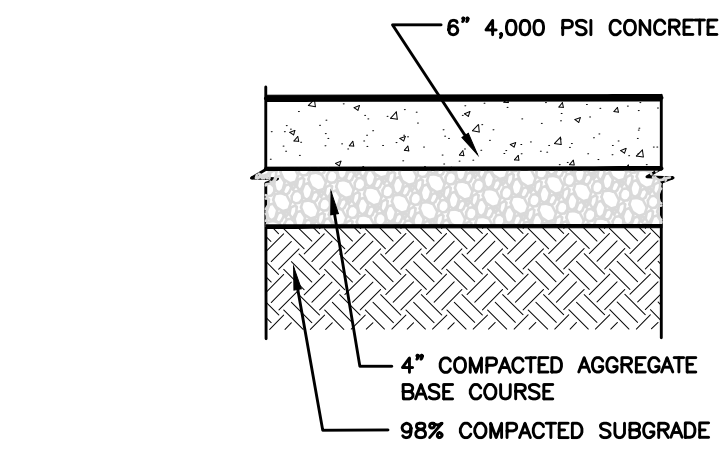
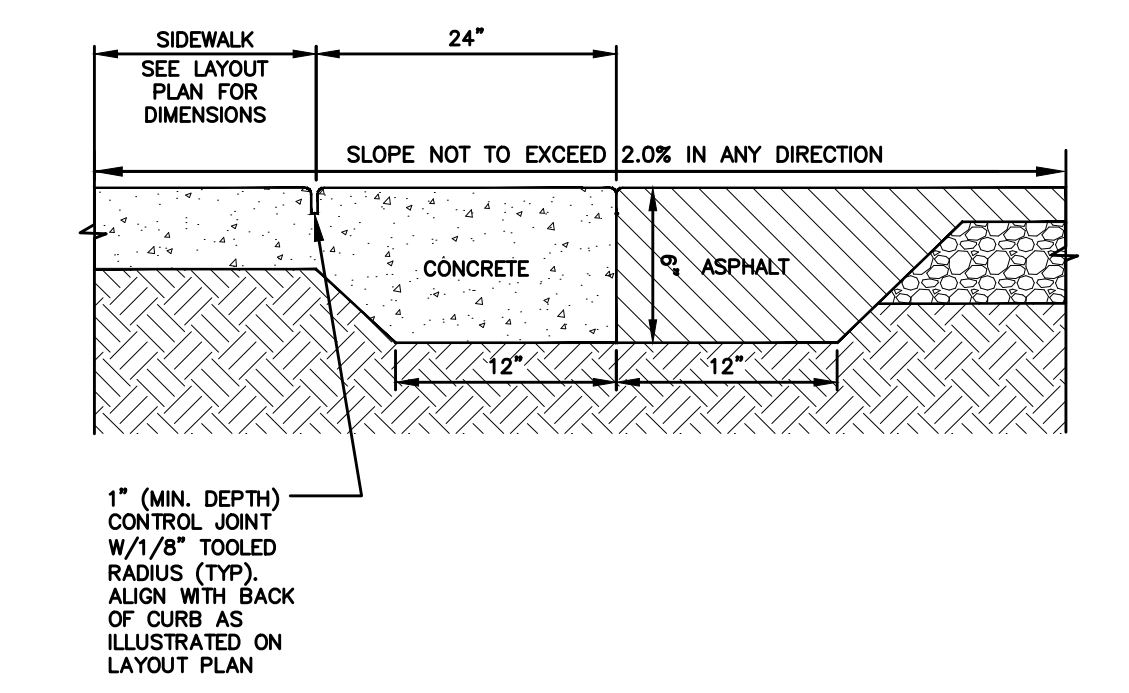

- CONCRETE NOTES:**
- UNLESS NOTED OTHERWISE, ALL CONCRETE SHALL ATTAIN A MINIMUM COMPRESSIVE STRENGTH OF 3000 PSI AT 28 DAYS.
  - AGGREGATES SHALL BE NATURAL SAND AND ROCK CONFORMING TO ASTM C33.
  - CEMENT SHALL BE PORTLAND CEMENT CONFORMING TO ASTM C-150, TYPE I OR II, LOW ALKALI OR AS REQUIRED TO SATISFY SITE SOIL CONDITIONS AS DETERMINED BY THE PROJECT SOILS ENGINEER.
  - WATER SHALL BE POTABLE, CLEAN AND FREE FROM INJURIOUS AMOUNTS OF OIL, ACIDS, ALKALIS, SALTS, ORGANIC MATERIALS, OR OTHER SUBSTANCES THAT MAY BE DELETERIOUS TO CONCRETE OR REINFORCEMENT.
  - ADMIXTURES TO BE USED IN CONCRETE SHALL BE SUBJECT TO PRIOR APPROVAL BY THE ENGINEER.
  - MAXIMUM PERMISSIBLE WATER-CEMENT RATIOS FOR CONCRETE WHEN STRENGTH DATA FROM TRIAL BATCHES ARE NOT AVAILABLE SHALL CONFORM TO TABLE 4.5 OF ACI STANDARD 318-77 OR BASED ON SULFATE CONTENT OF THE SITE SOILS, AS DETERMINED BY THE SOILS ENGINEER. THE LOWER WATER-CEMENT RATIO SHALL GOVERN.
  - CONCRETE SHALL BE CURED WHILE IN A MOIST CONDITION FOR AT LEAST THE FIRST 7 DAYS AFTER PLACEMENT. METHODS FOR ACCELERATED CURING SHALL HAVE PRIOR APPROVAL OF THE ENGINEER.
  - THE FOLLOWING MINIMUM CLEAR DISTANCES BETWEEN REINFORCING STEEL AND FACE OF CONCRETE SHALL BE MAINTAINED UNLESS NOTED OTHERWISE:  
 SLABS ON GRADE.....2"  
 CONCRETE BELOW GRADE, FORMED.....2"  
 CONCRETE BELOW GRADE, UNFORMED (POURED AGAINST EARTH).....3"  
 CONCRETE EXPOSED TO WEATHER.....1-1/2"

**3 CONCRETE NOTES**  
NOT TO SCALE

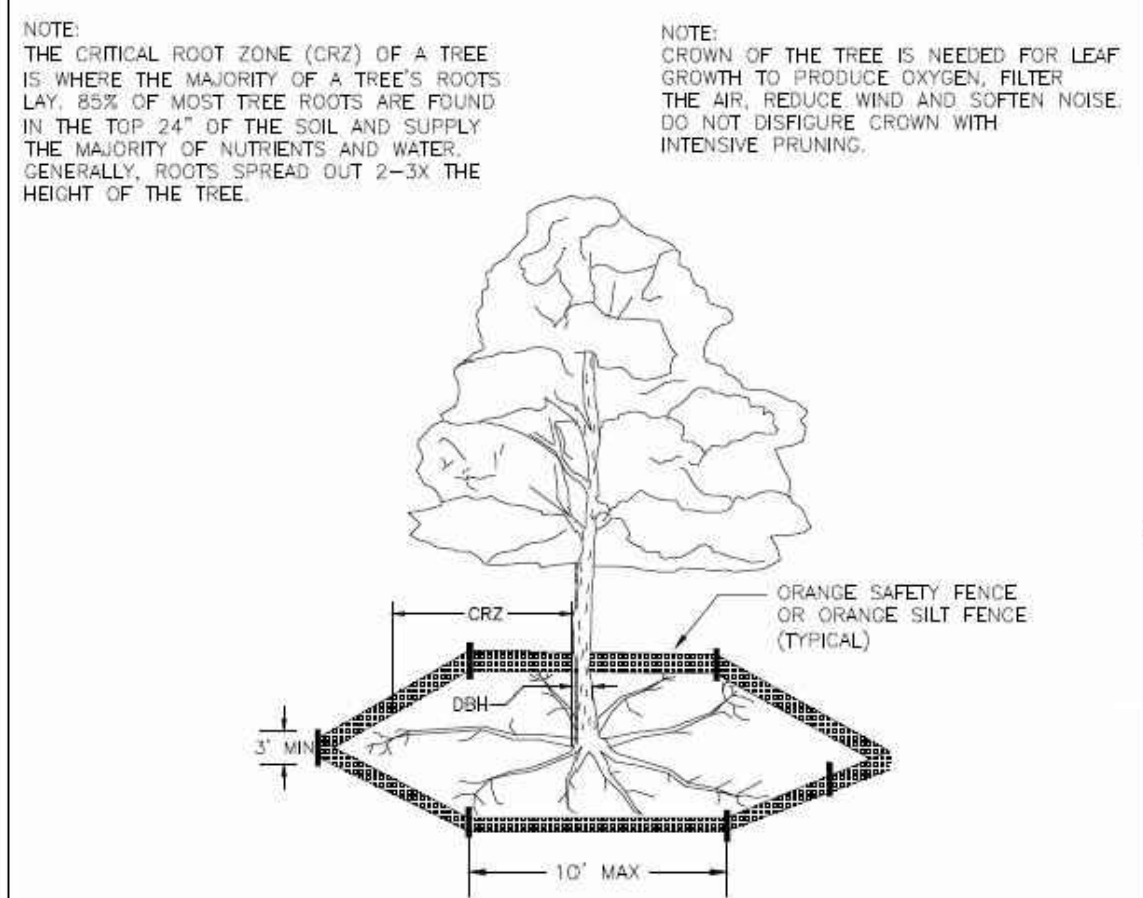
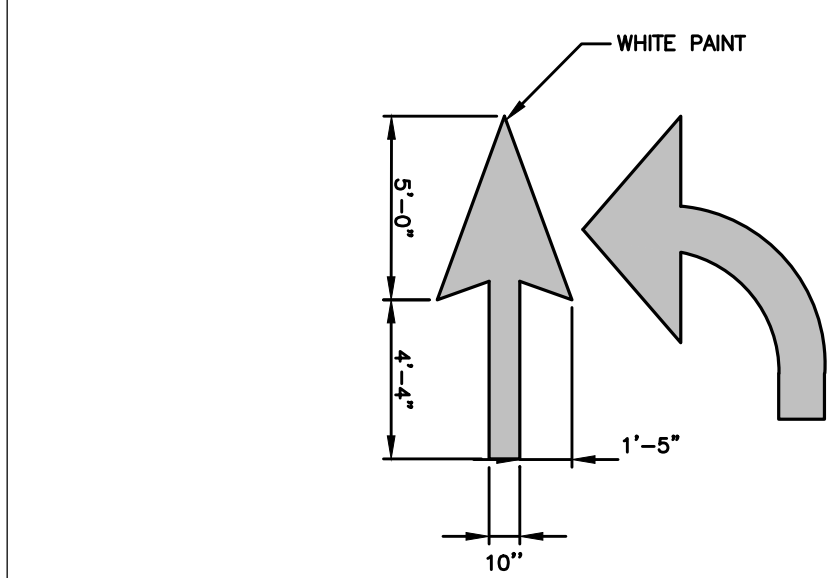

**STANDARD DETAIL  
TREE PROTECTION DURING CONSTRUCTION**  
SD 15-09

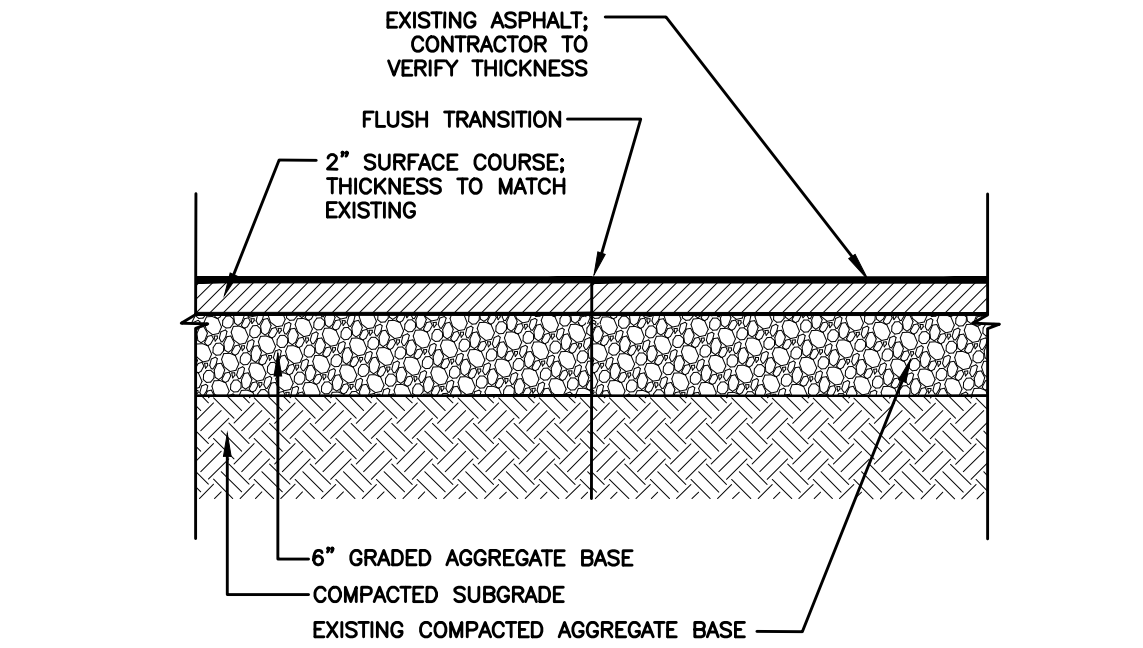

**LITTLE**  
DIVERSIFIED ARCHITECTURAL CONSULTING

5815 Westpark Drive Charlotte, NC 28217  
T: 704.525.6350 F: 704.561.8700  
www.littleonline.com

This drawing and the design shown are the property of Little Diversified Architectural Consulting. The reproduction, copying or other use of this drawing without their written consent is prohibited and any infringement will be subject to legal action.

© Little 2014

**WELLS FARGO**

**LITTLE DIVERSIFIED ARCHITECTURAL CONSULTING, INC.**  
REGISTERED ARCHITECTURAL CONSULTING FIRM  
NORTH CAROLINA  
CHARLOTTE, NC  
CERT. NO. 50033

**NORTH CAROLINA**  
REGISTERED LANDSCAPE ARCHITECTURE FIRM  
No. 1053  
DENVER, CO

6-10-14

ISSUE FOR

ISSUE DATE  
**06 JUNE 2014**

NO.	REVISIONS	DATE
01	06/06/2014 PRICING DOCUMENTS	
02	06/09/2014 PLANNING SUBMITTAL	
03	07/11/2014 PLANNING RE-SUBMITTAL	
04	07/11/2014 NCDOT RE-SUBMITTAL	

PROJECT TEAM  
PRINCIPAL IN CHARGE  
**Nancy Everhart, AIA, LEED AP**  
PROJECT MANAGER  
**Dennis C. Terry, RLA**  
DESIGN TEAM

PROJECT NAME  
**WELLS FARGO**  
**4195 MARKET ST.**  
**WILMINGTON, NC**

PROJECT NUMBER  
**123.2814.00**

SHEET TITLE  
**SITE DETAILS**

SHEET NUMBER  
**C5.00**





6-10-14

ISSUE DATE  
**06 JUNE 2014**

NO.	REVISIONS	DATE
01	06/06/2014 PRICING DOCUMENTS	
02	06/09/2014 PLANNING SUBMITTAL	
03	07/11/2014 PLANNING RE-SUBMITTAL	
04	07/11/2014 NCDOT RE-SUBMITTAL	

PROJECT TEAM  
PRINCIPAL IN CHARGE  
Nancy Everhart, AIA, LEED AP  
PROJECT MANAGER  
Dennis C. Terry, RLA  
DESIGN TEAM

PROJECT NAME  
**WELLS FARGO**  
4195 MARKET ST.  
WILMINGTON, NC

PROJECT NUMBER  
123.2814.00  
SHEET TITLE  
EROSION CONTROL DETAILS

SHEET NUMBER  
**C5.01**

STATE OF NORTH CAROLINA  
DEPT. OF TRANSPORTATION  
DIVISION OF HIGHWAYS  
RALEIGH, N.C.

ENGLISH STANDARD DRAWING FOR  
PAVEMENT REPAIRS  
FOR SUPERPAVE MIX TYPES

STATE OF NORTH CAROLINA  
DEPT. OF TRANSPORTATION  
DIVISION OF HIGHWAYS  
RALEIGH, N.C.

ENGLISH STANDARD DRAWING FOR  
PAVEMENT REPAIRS  
FOR SUPERPAVE MIX TYPES

65A.01

D	X	W
12"	1'-4"	7'-4"
15"	1'-7"	7'-7"
18"	1'-10"	7'-10"
24"	2'-6"	8'-6"
30"	3'-1"	9'-1"
36"	3'-8"	9'-8"
42"	4'-5"	10'-5"
48"	5'-0"	11'-0"

PAVEMENT REPAIRS ON ROADS NOT TO BE RESURFACED  
(PIPE IS TO BE PLACED UNDER EXISTING PAVEMENT)

PAVEMENT REPAIRS ON ROADS TO BE RESURFACED  
(PIPE IS PLACED UNDER EXISTING PAVEMENT)

ENGLISH STANDARD DRAWING FOR  
PAVEMENT REPAIRS  
FOR SUPERPAVE MIX TYPES

STATE OF NORTH CAROLINA  
DEPT. OF TRANSPORTATION  
DIVISION OF HIGHWAYS  
RALEIGH, N.C.

ENGLISH STANDARD DRAWING FOR  
PAVEMENT REPAIRS  
FOR SUPERPAVE MIX TYPES

65A.01

STATE OF NORTH CAROLINA  
DEPT. OF TRANSPORTATION  
DIVISION OF HIGHWAYS  
RALEIGH, N.C.

ENGLISH STANDARD DRAWING FOR  
CONCRETE CURB, GUTTER  
AND CURB & GUTTER

STATE OF NORTH CAROLINA  
DEPT. OF TRANSPORTATION  
DIVISION OF HIGHWAYS  
RALEIGH, N.C.

ENGLISH STANDARD DRAWING FOR  
CONCRETE CURB, GUTTER  
AND CURB & GUTTER

846.01

PLAN VIEW OF TYPICAL CURB AND GUTTER OCCURRENCES

PLAN VIEW OF TRANSITION  
EXPRESSWAY GUTTER TO 2'-6" CURB AND GUTTER

NOTES:  
1. IN THE TRANSITION FROM 4'-0" CONCRETE EXPRESSWAY GUTTER TO 2'-6" CONCRETE CURB AND GUTTER, PLACE 1/2" EXPANSION JOINTS AT 25' INTERVALS.  
2. PLACE GROOVE JOINTS 1" DEEP AT 12'-6" INTERVALS BETWEEN EXPANSION JOINTS. FILL AND SEAL THE TOP 1/2" OF THE EXPANSION JOINTS AND 1" OF CONTRACTION JOINTS WITH APPROVED JOINT SEALING COMPOUND.

STATE OF NORTH CAROLINA  
DEPT. OF TRANSPORTATION  
DIVISION OF HIGHWAYS  
RALEIGH, N.C.

ENGLISH STANDARD DRAWING FOR  
CONCRETE SIDEWALK

STATE OF NORTH CAROLINA  
DEPT. OF TRANSPORTATION  
DIVISION OF HIGHWAYS  
RALEIGH, N.C.

ENGLISH STANDARD DRAWING FOR  
CONCRETE SIDEWALK

848.01

NOTES:  
CONSTRUCT STANDARD SIDEWALK 5' WIDE AND 4" THICK UNLESS OTHERWISE DENOTED ON PLANS.  
PLACE A GROOVE JOINT 1" DEEP WITH 1/8" RADII IN THE CONCRETE SIDEWALK AT 5' INTERVALS. ONE 1/2" EXPANSION JOINT WILL BE REQUIRED AT 50' INTERVALS. A 1/2" EXPANSION JOINT WILL BE REQUIRED WHERE THE SIDEWALK JOINS ANY RIGID STRUCTURE.  
SEE STD. DWG. 848.05 FOR WHEELCHAIR RAMP LOCATION REQUIREMENTS AND CONSTRUCTION GUIDELINES.

TRANSVERSE EXPANSION JOINT  
IN SIDEWALK

PLAN VIEW

DETAILS SHOWING JOINTS IN CONCRETE SIDEWALK

STATE OF NORTH CAROLINA  
DEPT. OF TRANSPORTATION  
DIVISION OF HIGHWAYS  
RALEIGH, N.C.

ENGLISH STANDARD DRAWING FOR  
BRICK CATCH BASIN  
12" THRU 54" PIPE

STATE OF NORTH CAROLINA  
DEPT. OF TRANSPORTATION  
DIVISION OF HIGHWAYS  
RALEIGH, N.C.

ENGLISH STANDARD DRAWING FOR  
BRICK CATCH BASIN  
12" THRU 54" PIPE

840.01

PLAN

SECTION X-X

SECTION Y-Y

SECTION J-J

SECTION M-M

DETAIL SHOWING METHOD  
OF RISER CONSTRUCTION

NOTES:  
1. MORTAR JOINTS 1/2" x 1/4" THICK. USE CLASS "N" CONCRETE THROUGHOUT.  
2. USE FORM FOR CONSTRUCTION OF THE BOTTOM BLANK. DEDUCT FOR PIPES (S) FROM TOTAL G.W. OF BRICK MASONRY.  
3. USE #4 BAR FORMS AT 12" CENTERS.  
4. PROVIDE ALL GUTTER BASINS OVER 3'-0" IN WIDTH WITH STEPS 12" ON CENTER. USE STEPS WHICH COMPLY WITH STD. DRAWING 840.56. USE TYPE "T", "F" AND "G" GUTTER UNLESS OTHERWISE INDICATED.  
5. BRICKS ON CONCRETE BLOCK WHICH COMBLES WITH THE REQUIREMENTS OF SECTION 840 BY THE STANDARD SPECIFICATIONS.  
6. IF REINFORCED CONCRETE PIPE IS SET IN MORTAR SLAB OR BOX, ADD TO SLAB AS SHOWN ON STD. NO. 840.05.  
7. FOR 6'-0" IN HEIGHT OR LESS, USE #4 WALL OVER 8'-0" IN HEIGHT, USE #5 WALL OVER 8'-0" IN HEIGHT AND #6 WALL FOR THE REMAINING 6'-0" HEIGHTS. WALLS TO BE ADJUSTED ACCORDINGLY.  
8. CONTRACTOR SHALL GUARANTEE TO MAINTAIN THE FINISHING SURFACE OF ALL EXPOSED CORNERS 1".  
DRAWING NOT TO SCALE.

STATE OF NORTH CAROLINA  
DEPT. OF TRANSPORTATION  
DIVISION OF HIGHWAYS  
RALEIGH, N.C.

ENGLISH STANDARD DRAWING FOR  
BRICK CATCH BASIN  
12" THRU 54" PIPE

STATE OF NORTH CAROLINA  
DEPT. OF TRANSPORTATION  
DIVISION OF HIGHWAYS  
RALEIGH, N.C.

ENGLISH STANDARD DRAWING FOR  
BRICK CATCH BASIN  
12" THRU 54" PIPE

840.01

PLAN

ELEVATION

SECTION S-S

SECTION R-R

DOWEL

MINIMUM DIMENSIONS AND QUANTITIES FOR BRICK CATCH BASIN (BASED ON MIN. HEIGHT, H, WITH NO RISER)		TOP SLAB		BAR-U		BAR-V		BAR-W		TOTAL		G.W. CONC. IN BOX		BRICK MASONRY		DESIGN LOADS	
SIZE	SPACE	THICKNESS	SPACING	NO.	LENGTH	NO.	LENGTH	NO.	LENGTH	NO.	LENGTH	NO.	LENGTH	NO.	LENGTH	NO.	LENGTH
12"	3'-0"	2'-2"	2'-2"	2	2'-2"	2	2'-2"	2	2'-2"	6	2'-2"	6	2'-2"	12	2'-2"	12	0.581
18"	3'-0"	2'-2"	2'-2"	3	2'-2"	3	2'-2"	3	2'-2"	9	2'-2"	9	2'-2"	18	2'-2"	18	0.863
24"	3'-0"	2'-2"	2'-2"	4	2'-2"	4	2'-2"	4	2'-2"	12	2'-2"	12	2'-2"	24	2'-2"	24	1.145
30"	3'-0"	2'-2"	2'-2"	5	2'-2"	5	2'-2"	5	2'-2"	15	2'-2"	15	2'-2"	30	2'-2"	30	1.427
36"	3'-0"	2'-2"	2'-2"	6	2'-2"	6	2'-2"	6	2'-2"	18	2'-2"	18	2'-2"	36	2'-2"	36	1.709
42"	3'-0"	2'-2"	2'-2"	7	2'-2"	7	2'-2"	7	2'-2"	21	2'-2"	21	2'-2"	42	2'-2"	42	1.991
48"	3'-0"	2'-2"	2'-2"	8	2'-2"	8	2'-2"	8	2'-2"	24	2'-2"	24	2'-2"	48	2'-2"	48	2.273
54"	3'-0"	2'-2"	2'-2"	9	2'-2"	9	2'-2"	9	2'-2"	27	2'-2"	27	2'-2"	54	2'-2"	54	2.555

TEMPORARY SEEDING

SOIL AMENDMENTS

FOLLOW RECOMMENDATIONS OF SOIL TEST OR APPLY 2,000 LB / ACRE GROUND AGRICULTURAL LIMESTONE AND 750 LB / ACRE 10-10-10 LIMESTONE. APPLY FERTILIZER AND LIMESTONE UNIFORMLY AND INCORPORATE TOP 4-6 INCHES OF SOIL. IF A HYDRAULIC SEEDER IS USED, DO NOT MIX SEED AND FERTILIZER MORE THAN 30 MINUTES PRIOR TO APPLICATION.

MULCH

APPLY 4,000 LB / ACRE STRAW. ANCHOR STRAW BY TACKING WITH ASPHALT, NETTING, OR A MULCH ANCHORING TOOL. A DISK WITH BLADES SET NEARLY STRAIGHT CAN BE USED AS A MULCH ANCHORING TOOL.

MAINTENANCE

RESEED AND MULCH AREAS WHERE SEEDLING EMERGENCE IS POOR, OR WHERE EROSION OCCURS, AS SOON AS POSSIBLE. DO NOT MOW. PROTECT FROM TRAFFIC AS MUCH AS POSSIBLE.

SEEDING MIXTURES

LATE WINTER - EARLY SPRING:

SPECIES	RATE (LB / ACRE)
RYE (GRAIN)	120
ANNUAL LESPEDEZA (KOBE IN PIEDMONT AND COASTAL PLAIN, KOREAN IN MOUNTAINS)	50

OMIT ANNUAL LESPEDEZA WHEN DURATION OF TEMPORARY COVER IS NOT TO EXTEND BEYOND JUNE.

SEEDING DATES (PIEDMONT): JAN. 1 - MAY 1

SUMMER:

SPECIES	RATE (LB / ACRE)
GERMAN MILLET	40

IN THE PIEDMONT AND MOUNTAINS, A SMALL-STEMMED SUDAGRASS MAY BE SUBSTITUTED AT A RATE OF 50 LB / ACRE.

SEEDING DATES (PIEDMONT): MAY 1 - AUG. 15

FALL:

SPECIES	RATE (LB / ACRE)
RYE (GRAIN)	120

SEEDING DATES (PIEDMONT): AUG. 15 - DEC. 30

SPECIAL MAINTENANCE PRACTICES: REPAIR AND FERTILIZE DAMAGED AREAS IMMEDIATELY. TOPDRESS WITH 50 LB / ACRE OF NITROGEN IN MARCH. IF IT IS NECESSARY TO EXTEND TEMPORARY COVER BEYOND JUNE 15, OVERSEED WITH 50 LB / ACRE KOBE (PIEDMONT) LESPEDEZA IN LATE FEBRUARY OR EARLY MARCH.

PERMANENT SEEDING

SPECIES

SPECIES	RATE (LB / ACRE)
TALL FESCUE	80
SERICA LESPEDEZA	20
KOBE LESPEDEZA	10

SEEDING NOTES

- AFTER AUG. 15, USE UNSCARIFIED SERICEA SEED.
- WHERE PERIODIC MOWING IS PLANNED OR WHERE A NEAT APPEARANCE IS DESIRED, OMIT SERICEA AND INCREASE KOBE LESPEDEZA TO 40 LB / ACRE.
- TO EXTEND SPRING SEEDING DATES INTO JUNE, ADD 15 LB / ACRE HULLED BERMUDAGRASS. HOWEVER, AFTER MID-APRIL IT IS PREFERABLE TO SEED TEMPORARY COVER.

NURSE PLANTS

BETWEEN MAY 1 AND AUGUST 15, ADD 10 LB / ACRE GERMAN MILLET OR 15 LB / ACRE SUDAGRASS. PRIOR TO MAY 1 OR AFTER AUGUST 15, ADD 40 LB / ACRE RYE (GRAIN).

SEEDING DATES

BEST	POSSIBLE
FALL AUG. 25 - SEPT. 15 LATE WINTER FEB. 15 - MAR. 21	AUG. 20 - OCT. 25 FEB. 1 - APR. 15

FALL IS BEST FOR TALL FESCUE, AND LESPEDEZAS IN LATE WINTER. OVERSEEDING OF KOBE LESPEDEZA OVER FALL-SEEDED TALL FESCUE IS VERY EFFECTIVE. USE UNHULLED BERMUDAGRASS SEED IN FALL.

SOIL AMENDMENTS

APPLY LIME AND FERTILIZER ACCORDING TO SOIL TESTS, OR APPLY 4,000 LB / ACRE GROUND AGRICULTURAL LIMESTONE AND 1,000 LB / ACRE 10-10-10 FERTILIZER.

MULCH

APPLY 4,000 LB / ACRE GRAIN STRAW OR EQUIVALENT COVER OF ANOTHER SUITABLE MULCHING MATERIAL. ANCHOR MULCH BY TACKING WITH ASPHALT, ROWING, NETTING OR ROWING OR BY CRIMPING WITH A MULCH ANCHORING TOOL. A DISK WITH BLADES SET NEARLY STRAIGHT CAN BE USED AS A MULCH ANCHORING TOOL.

MAINTENANCE

REFERTILIZE IN THE SECOND YEAR UNLESS GROWTH IS FULLY ADEQUATE. MAY BE MOWED ONCE OR TWICE A YEAR, BUT MOWING IS NOT NECESSARY. RESEED, FERTILIZE, AND MULCH DAMAGED AREAS IMMEDIATELY.

REFER TO APPENDIX B OR OF NCDENR'S EROSION AND SEDIMENT CONTROL PLANNING AND DESIGN MANUAL FOR BOTANICAL NAMES.

3 NCDENR SEEDING SPECIFICATIONS

INLET PROTECTION

NOT TO SCALE

GENERAL NOTES

- FENCE FABRIC SHALL BE A MINIMUM OF 32" IN WIDTH AND SHALL HAVE A MINIMUM OF 6 LINE WIRES WITH 12" SPACING.
- FILTER FABRIC SHALL BE MIRAFI 140 FABRIC OR EQUIVALENT.
- BURLAP CANNOT BE USED WHERE SILT FENCE IS TO REMAIN FOR A PERIOD OF MORE THAN 30 DAYS.
- STEEL POST SHALL BE 5" IN HEIGHT AND BE OF THE SELF-FASTENER ANGLE STEEL TYPE.
- WOOD POST SHALL BE 6" IN HEIGHT AND 4" IN DIAMETER.
- WIRE FABRIC SHALL BE FASTENED TO WOODEN POST WITH NOT LESS THAN #9 WIRE STAPLES 1 1/2" LONG.

1 SILT FENCE

NOT TO SCALE

SILT FENCE

NOT TO SCALE

MAINTENANCE NOTES

- FENCE BARRIERS SHALL BE INSPECTED IMMEDIATELY AFTER EACH RAINFALL AND AT LEAST DAILY DURING PROLONGED RAINFALL. ANY REQUIRED REPAIRS SHALL BE MADE IMMEDIATELY.
- SHOULD THE FABRIC DECOMPOSE OR BECOME INEFFECTIVE PRIOR TO THE END OF THE EXPECTED USABLE LIFE AND THE BARRIER STILL BE NECESSARY, THE FABRIC SHALL BE REPLACED PROMPTLY.
- SEDIMENT DEPOSITS SHOULD BE REMOVED AFTER EACH STORM EVENT AND WHEN THEY DEPOSITS REACH APPROXIMATELY HALF THE HEIGHT OF THE BARRIER.
- ANY SEDIMENT DEPOSITS REMAINING IN PLACE AFTER THE SILT FENCE OR FILTER BARRIER IS NO LONGER REQUIRED SHALL BE DRESSED TO CONFORM WITH THE EXISTING GRADE, PREPARED AND SEED.

APPROVED PLAN - NO PERMIT REQUIRED

Signed: \_\_\_\_\_

WILMINGTON NORTH CAROLINA  
Public Services • Engineering Division



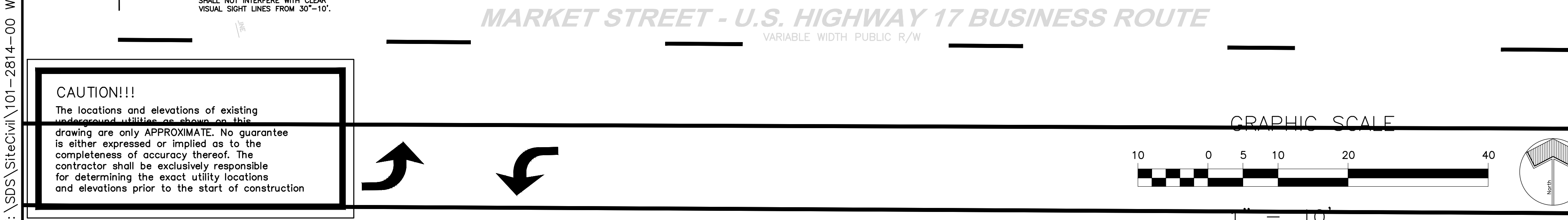
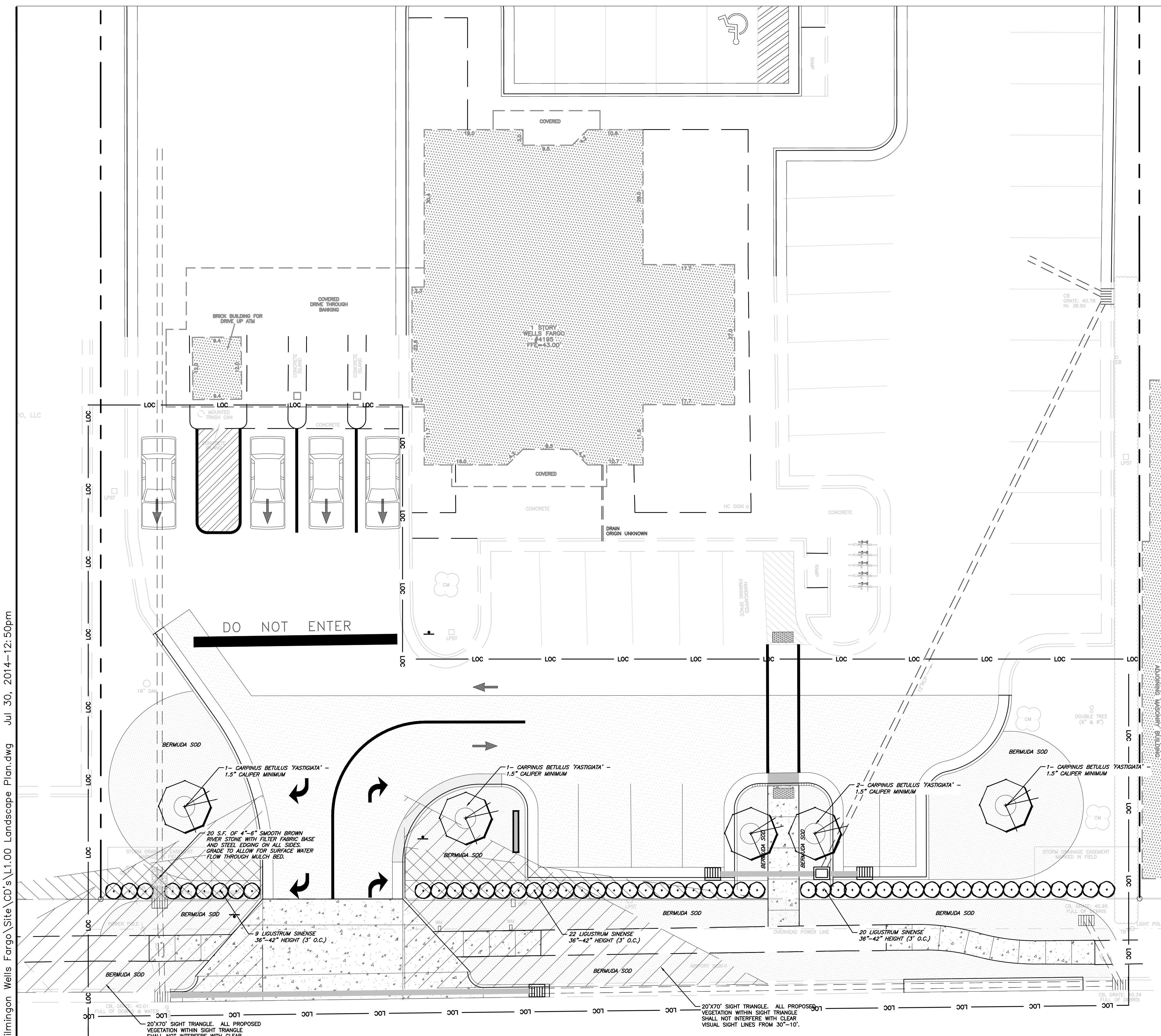

**IRRIGATION REQUIREMENTS**

CONTRACTOR SHALL DESIGN AND INSTALL A COMPLETE FUNCTIONING IRRIGATION SYSTEM FOR ALL TURF AND PLANTING AREAS, WITHIN PROJECT CONSTRUCTION LIMITS. CONTRACTOR SHALL SUBMIT IRRIGATION PLANS FOR ENTIRE SYSTEM TO ARCHITECT FOR REVIEW AND APPROVAL PRIOR TO INSTALLATION. PLANS SHALL INCLUDE A COMPLETE SEPARATION OF SHRUB AND TURF AREAS. PLANS SHALL INCLUDE CONTROLLER, ALL SLEEVING, ELECTRIC VALVES, HEADS, LATERALS, MAINS, DRIP LINE CONNECTIONS TO EQUIPMENT, AND ALL OTHER COMPONENTS NECESSARY FOR A WORKING IRRIGATION SYSTEM. ALL CONTROLLERS, VALVES AND HEADS TO BE MADE BY THE SAME MANUFACTURER. BACKFLOW PREVENTOR TO BE PROVIDED BY CONTRACTOR AND SHALL CONFORM TO REQUIREMENTS OF LOCAL AUTHORITIES. SEE ELECTRICAL PLANS FOR LOCATION OF CONTROLLER BOX.

- IRRIGATION NOTES**
- CONTRACTOR SHALL VERIFY THAT AVAILABLE WATER PRESSURE IS ADEQUATE FOR IRRIGATION SYSTEM. CONTRACTOR SHALL VERIFY IN FIELD PRIOR TO BEGINNING CONSTRUCTION. ANY DISCREPANCIES SHALL BE REPORTED TO THE LANDSCAPE ARCHITECT OR OWNERS REPRESENTATIVE.
  - CONTRACTOR TO PROVIDE IRRIGATION LAYOUT DESIGN TO ARCHITECT FOR APPROVAL. SEE IRRIGATION REQUIREMENTS PARAGRAPH.
  - CONTRACTOR IS RESPONSIBLE FOR INSTALLATION OF WATER METERS, BACKFLOW PREVENTERS, VALVES, ELECTRIC WIRING FOR THE IRRIGATION SYSTEM, ALL SLEEVING, ALL FITTINGS, ADAPTERS, ETC. TO COMPLETE THE IRRIGATION SYSTEM.
  - CONTRACTOR SHALL ADJUST ALL HEADS IN FIELD TO INSURE MAXIMUM COVERAGE, ELIMINATE OVERTHROW ONTO PAVED AREAS, BUILDING AND WALL SURFACES. (LOCATE HEADS 3" CLEAR OF ALL HARDSCAPE SURFACES.) ALL AUTOMATIC VALVES SHALL BE INSTALLED IN A VALVE BOX AS SPECIFIED. COORDINATE SLEEVES WITH GENERAL CONTRACTOR.
  - CONTRACTOR SHALL COORDINATE PIPING LAYOUT WITH LANDSCAPE PLAN TO INSURE PIPES DO NOT INTERFERE WITH ROOT BALLS OF TREES OR ROWS OF SHRUBS. REPORT ANY DISCREPANCIES TO THE LANDSCAPE ARCHITECT OR OWNERS REPRESENTATIVE.
  - CONTRACTOR SHALL VERIFY THAT ALL PERTINENT LOCAL AND STATE CODES ARE BEING OBSERVED.
  - CONTRACTOR TO PROVIDE THRUST BLOCKS ON MAIN LINE AT ALL BENDS AND TURNS.
  - IRRIGATE ALL TREES WITHIN PROJECT LIMITS.
  - PROVIDE GATE VALVES AT DOWNSTREAM SIDE OF BACKFLOW AND AT HYDRAULIC CONTROLLERS.

- GENERAL PLANTING NOTES:**
- ANY DEVIATION FROM THESE PLANS MUST BE SPECIFICALLY APPROVED BY LANDSCAPE ARCHITECT OR OWNER'S REPRESENTATIVE.
  - NOTIFY LANDSCAPE ARCHITECT OF ANY SITE CONDITIONS WHICH MAY NECESSITATE MODIFICATION TO THE PLAN. LANDSCAPE ARCHITECT SHALL, IF NECESSARY, MAKE "IN-FIELD MODIFICATIONS".
  - FINE GRADING SHALL CONSIST OF HAND RAKED SMOOTH, FREE OF DEBRIS, ALL AREAS TO RECEIVE LANDSCAPE PLANTING AND/OR PINESTRAW MULCH.
  - CONTRACTOR IS RESPONSIBLE FOR INSPECTION OF EXISTING CONDITIONS AND PROMPTLY REPORTING ANY DISCREPANCIES. CONTRACTOR TO PERFORM SOIL TESTS AS NECESSARY TO CONFORM TO SPECIFICATIONS.
  - CONTRACTOR IS RESPONSIBLE FOR LOCATING EXISTING UTILITIES AND ANY DAMAGE HE IS RESPONSIBLE FOR THAT MAY OCCUR TO EXISTING UTILITIES.
  - MULCH ALL PLANTING BEDS WITH HARDWOOD MULCH TO A 3" DEPTH (MATCH EXISTING MULCH).
  - CONTRACTOR TO VERIFY THAT ALL PLANT MATERIAL IS AVAILABLE AS SPECIFIED WHEN BID/PROPOSAL IS SUBMITTED.
  - PLANT SCHEDULE WAS PREPARED FOR ESTIMATING PURPOSES. CONTRACTOR SHALL MAKE OWN QUANTITIES TAKEOFF USING DRAWINGS TO DETERMINE QUANTITIES TO HIS SATISFACTION, REPORTING PROMPTLY ANY DISCREPANCIES WHICH MAY AFFECT BIDDING. GRAPHIC REPRESENTATION OF PLANTS SHALL SUPERCEDE QUANTITIES LISTED IN THE PLANT SCHEDULE.
  - ROOT TYPE MAY BE FREELY SUBSTITUTED IN CASE OF BALLED AND BURLAPPED OR CONTAINER GROWN, OTHER SPECIFICATIONS REMAINING UNCHANGED, EXCEPT IN THE CASE OF CONTAINER GROWN SPECIMEN TREES AS INDICATED IN THE TREE PLANTING SCHEDULE.
  - ALL PLANTING BEDS TO RECEIVE AN AMENDED SOIL MIXTURE. SOIL MIX SHALL BE COMPOSED OF 75% EXISTING SOIL AND 15% ORGANIC MATERIAL (OR APPROVED EQUAL) AND 10% SAND. SUPPLEMENT SOIL MIX WITH HIGHER CONCENTRATION OF NITROGEN.
  - LANDSCAPE CONTRACTOR TO APPLY A PRE-EMERGENT HERBICIDE, 'PREEN' OR EQUAL TO ALL PLANT BED AREAS.
  - IN ADDITION TO THE SOIL MIXTURE, LANDSCAPE CONTRACTOR IS RESPONSIBLE FOR PROVIDING AND INSTALLING ANY NECESSARY SOIL AMENDMENTS, AS INDICATED BY SOIL TESTS, AS WELL AS AN ADEQUATE DRAINAGE SYSTEM FOR PLANTING BEDS. LANDSCAPE CONTRACTOR IS RESPONSIBLE FOR PROVIDING AN ENVIRONMENT SUITABLE FOR THE GROWTH OF HEALTHY PLANT MATERIAL.
  - REFER TO PLANTING DETAILS FOR INFORMATION ON PLANTING BED PREPARATIONS. ALL AREAS NOT DESIGNATED AS PLANTING BEDS OR SOD ARE TO BE SEEDED WITH GRASS SEED WITH THE WITH THE INTENT AND PURPOSE OF ESTABLISHING A PERMANENT STAND OF GRASS.
  - ALL PLANT MATERIAL MUST BE PLANTED IN CORRELATION WITH THE APPROPRIATE GROWING SEASON OF INDIVIDUAL PLANT REQUIREMENTS. SOME PERENNIALS MAY REQUIRE A SPRING PLANTING IN ORDER TO SURVIVE A FULL WINTER DORMANCY.
  - PROVIDE QUALITY, SIZE, GENUS, SPECIES AND VARIETY OF EXTERIOR PLANTS INDICATED, COMPLYING WITH APPLICABLE REQUIREMENTS IN ANSI 260.1, 'AMERICAN STANDARD FOR NURSERY STOCK.
  - ALL PLANT MATERIAL AND WORKMANSHIP TO BE GUARANTEED FOR ONE YEAR FROM THE DATE OF ACCEPTANCE BY THE OWNER. PLANT REPLACEMENT TO OCCUR ONLY ONCE, EXCEPT FOR LOSSES OR REPLACEMENTS DUE TO FAILURE TO COMPLY WITH REQUIREMENTS. REPLACEMENT PLANTS SHALL BE INSTALLED IN ACCORDANCE WITH THE REQUIREMENTS OF THIS DOCUMENT. THE CONTRACTOR WILL NOT BE RESPONSIBLE FOR DEFECTS RESULTING FROM NEGLIGENCE BY THE OWNER, ABUSE OR DAMAGE BY OTHERS, OR UNUSUAL PHENOMENA OR INCIDENTS BEYOND THE LANDSCAPE CONTRACTOR'S CONTROL, WHICH RESULT FROM NATURAL CAUSES.
  - MINIMUM TREE SIZE AT PLANTING IS 3-INCH CALIPER (FOR SINGLE STEM TREES).
  - ALL STRAPPING AND TOP 2/3 OF WIRE BASKET MUST BE CUT AWAY AND REMOVED FROM ROOT BALL PRIOR TO BACKFILLING AND PLANTING PIT. REMOVE ALL PAVEMENT, GRAVEL, SUB-BASE AND CONSTRUCTION DEBRIS; REMOVE COMPACTED SOIL AND ADD 2" OF NEW TOPSOIL OR UNCOMPACT AND AMEND THE TOP 2" OF EXISTING SOIL TO MEET TOPSOIL/PLANTING MIX STANDARDS FOR TREES (WITHIN ENTIRE MINIMUM AREA OF SQUARE FEET PER TREE). CALL LANDSCAPE ARCHITECT FOR AN INSPECTION OF SOIL BEFORE PLANTING.
  - ADJUST PLANTING LOCATIONS TO AVOID UNDERGROUND UTILITIES. PLANT MINIMUM 15' OFF SEWER AND STORM DRAIN LINES; PLANT MIN. 10' OFF GAS, WATER, TELEPHONE, AND ELECTRICAL LINES.

**CAUTION!!!**  
 The locations and elevations of existing underground utilities shown on this drawing are only APPROXIMATE. No guarantee is either expressed or implied as to the completeness of accuracy thereof. The contractor shall be exclusively responsible for determining the exact utility locations and elevations prior to the start of construction

**LITTLE**  
 DIVERSIFIED ARCHITECTURAL CONSULTING  
 5815 Westpark Drive Charlotte, NC 28217  
 T: 704.525.6350 F: 704.561.8700  
 www.littleonline.com

*This drawing and the design shown are the property of Little Diversified Architectural Consulting. The reproduction, copying or other use of this drawing without their written consent is prohibited and any infringement will be subject to legal action.*

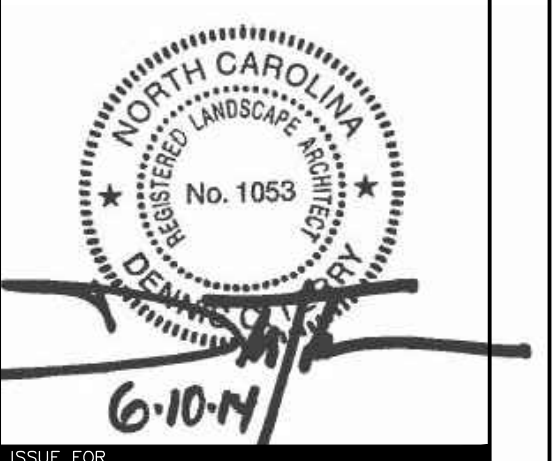
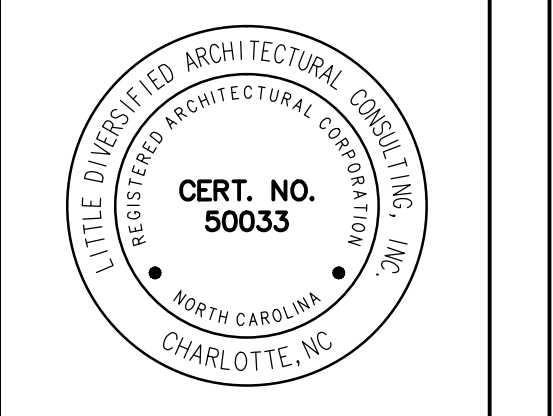

ISSUE FOR: 6-10-14

NO.	REVISION	DATE
01	06/06/2014 PRICING DOCUMENTS	
02	06/09/2014 PLANNING SUBMITTAL	
03	07/11/2014 PLANNING RE-SUBMITTAL	
04	07/11/2014 NCDOT RE-SUBMITTAL	
05	07/28/2014 PLANNING RE-SUBMITTAL	
06	07/28/2014 NCDOT RE-SUBMITTAL	

PROJECT TEAM  
 PRINCIPAL IN CHARGE: Nancy Everhart, AIA, LEED AP  
 PROJECT MANAGER: Dennis C. Terry, RLA  
 DESIGN TEAM:

PROJECT NAME  
**WELLS FARGO**  
 4195 MARKET ST.  
 WILMINGTON, NC

PROJECT NUMBER  
 123.2814.00  
 SHEET TITLE  
 LANDSCAPE PLAN

SHEET NUMBER  
**L1.00**

**CITY OF WILMINGTON**  
 NORTH CAROLINA  
 Public Services • Engineering Division  
 APPROVED PLAN - NO PERMIT REQUIRED  
 Signed: \_\_\_\_\_